

# KENWOOD

## **Document Copyrights**

Copyright 2006 by Kenwood Corporation. All rights reserved.

No part of this manual may be reproduced, translated, distributed, or transmitted in any form or by any means, electronic, mechanical, photocopying, recording, or otherwise, for any purpose without the prior written permission of Kenwood.

## **Disclaimer**

While every precaution has been taken in the preparation of this manual, Kenwood assumes no responsibility for errors or omissions. Neither is any liability assumed for damages resulting from the use of the information contained herein. Kenwood reserves the right to make changes to any products herein at any time for improvement purposes.

This service manual applies to products with 50800001 or subsequent serial numbers.  
In terms of the products with the serial numbers earlier than 50800001, refer to the TK-8102 service manual as per part No. B51-8585-00 and B51-8585-10.

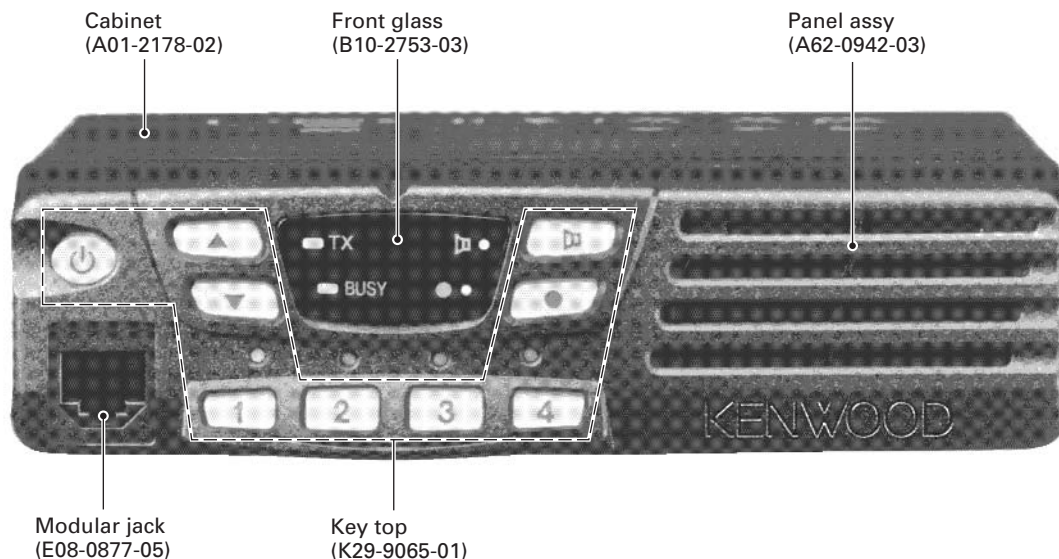

## CONTENTS

<b>GENERAL</b> .....	<b>2</b>	<b>PACKING</b> .....	<b>31</b>
<b>SYSTEM SET-UP</b> .....	<b>3</b>	<b>ADJUSTMENT</b> .....	<b>32</b>
<b>OPERATING FEATURES</b> .....	<b>4</b>	<b>TERMINAL FUNCTION</b> .....	<b>37</b>
<b>REALIGNMENT</b> .....	<b>8</b>	<b>PC BOARD</b>	
<b>INSTALLATION</b> .....	<b>12</b>	<b>DISPLAY UNIT (X54-3460-20)</b> .....	<b>38</b>
<b>DISASSEMBLY FOR REPAIR</b> .....	<b>15</b>	<b>TX-RX UNIT (X57-6920-XX)</b> .....	<b>40</b>
<b>CIRCUIT DESCRIPTION</b> .....	<b>16</b>	<b>SCHEMATIC DIAGRAM</b> .....	<b>44</b>
<b>SEMICONDUCTOR DATA</b> .....	<b>21</b>	<b>BLOCK DIAGRAM</b> .....	<b>48</b>
<b>COMPONENTS DESCRIPTION</b> .....	<b>22</b>	<b>LEVEL DIAGRAM</b> .....	<b>50</b>
<b>PARTS LIST</b> .....	<b>23</b>	<b>SPECIFICATION</b> .....	<b>BACK COVER</b>
<b>EXPLODED VIEW</b> .....	<b>30</b>		

### Service Manual List

Title	Parts number	Remarks	Destination	TX-RX unit number	Display unit number
TK-8102	B51-8585-00		M	X57-6300-20	X54-3340-20
TK-8102	B51-8585-10	REVISED	M,M2,M3	X57-6300-XX	X54-3340-20
TK-8102	B51-8585-20 (This service manual)	REVISED II	M,M2,M3	X57-6920-XX	X54-3460-20

## GENERAL

### INTRODUCTION

#### SCOPE OF THIS MANUAL

This manual is intended for use by experienced technicians familiar with similar types of commercial grade communications equipment. It contains all required service information for the equipment and is current as of this publication date. Changes which may occur after publication are covered by either Service Bulletins or Manual Revisions, which are issued as required.

### ORDERING REPLACEMENT PARTS

When ordering replacement parts or equipment information, the full part identification number should be included. This applies to all parts : components, kits, and chassis. If the part number is not known, include the chassis or kit number of which it is a part and a sufficient description of the required component for proper identification.

### PERSONAL SAFETY

The following precautions are recommended for personal safety :

- DO NOT transmit if someone is within two feet (0.6 meter) of the antenna.
- DO NOT transmit until all RF connectors are secure and any open connectors are properly terminated.
- SHUT OFF this equipment when near electrical blasting caps or while in an explosive atmosphere.
- All equipment should be properly grounded before power-up for safe operation.
- This equipment should be serviced by only qualified technicians.

### PRE-INSTALLATION CONSIDERATIONS

#### 1. UNPACKING

Unpack the radio from its shipping container and check for accessory items. If any item is missing, please contact KENWOOD immediately.

#### 2. LICENSING REQUIREMENTS

Federal regulations require a station license for each radio installation (mobile or base) be obtained by the equipment owner. The licensee is responsible for ensuring transmitter power, frequency, and deviation are within the limits permitted by the station license.

Transmitter adjustments may be performed only by a licensed technician holding an FCC first, second or general class commercial radiotelephone operator's license. There is no license required to install or operate the radio.

### 3. PRE-INSTALLATION CHECKOUT

#### 3-1. Introduction

Each radio is adjusted and tested before shipment. However, it is recommended that receiver and transmitter operation be checked for proper operation before installation.

#### 3-2. Testing

The radio should be tested complete with all cabling and accessories as they will be connected in the final installation. Transmitter frequency, deviation, and power output should be checked, as should receiver sensitivity, squelch operation, and audio output. Signalling equipment operation should be verified.

### 4. PLANNING THE INSTALLATION

#### 4-1. General

Inspect the vehicle and determine how and where the radio antenna and accessories will be mounted.

Plan cable runs for protection against pinching or crushing wiring, and radio installation to prevent overheating.

#### 4-2. Antenna

The favored location for an antenna is in the center of a large, flat conductive area, usually at the roof center. The trunk lid is preferred, bond the trunk lid and vehicle chassis using ground straps to ensure the lid is at chassis ground.

#### 4-3. Radio

The universal mount bracket allows the radio to be mounted in a variety of ways. Be sure the mounting surface is adequate to support the radio's weight. Allow sufficient space around the radio for air cooling. Position the radio close enough to the vehicle operator to permit easy access to the controls when driving.

#### 4-4. DC Power and wiring

1. This radio may be installed in negative ground electrical systems only. Reverse polarity will cause the cable fuse to blow. Check the vehicle ground polarity before installation to prevent wasted time and effort.
2. Connect the positive power lead directly to the vehicle battery positive terminal. Connecting the Positive lead to any other positive voltage source in the vehicle is not recommended.
3. Connect the ground lead directly to the battery negative terminal.
4. The cable provided with the radio is sufficient to handle the maximum radio current demand. If the cable must be extended, be sure the additional wire is sufficient for the current to be carried and length of the added lead.

## GENERAL / SYSTEM SET-UP

### 5. INSTALLATION PLANNING – CONTROL STATIONS

#### 5-1. Antenna system

Control station. The antenna system selection depends on many factors and is beyond the scope of this manual. Your KENWOOD dealer can help you select an antenna system that will best serve your particular needs.

#### 5-2. Radio location

Select a convenient location for your control station radio which is as close as practical to the antenna cable entry point. Secondly, use your system's power supply (which supplies the voltage and current required for your system). Make sure sufficient air can flow around the radio and power supply to allow adequate cooling.

### NOTE

If you do not intend to use the 3.5-mm jack for the external speaker, fit the supplied speaker-jack cap to stop dust and sand from getting in.

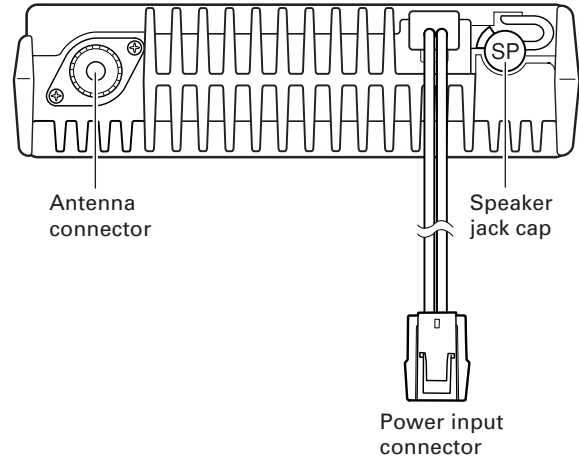

### SERVICE

This radio is designed for easy servicing. Refer to the schematic diagrams, printed circuit board views, and alignment procedures contained in this manual.

### SYSTEM SET-UP

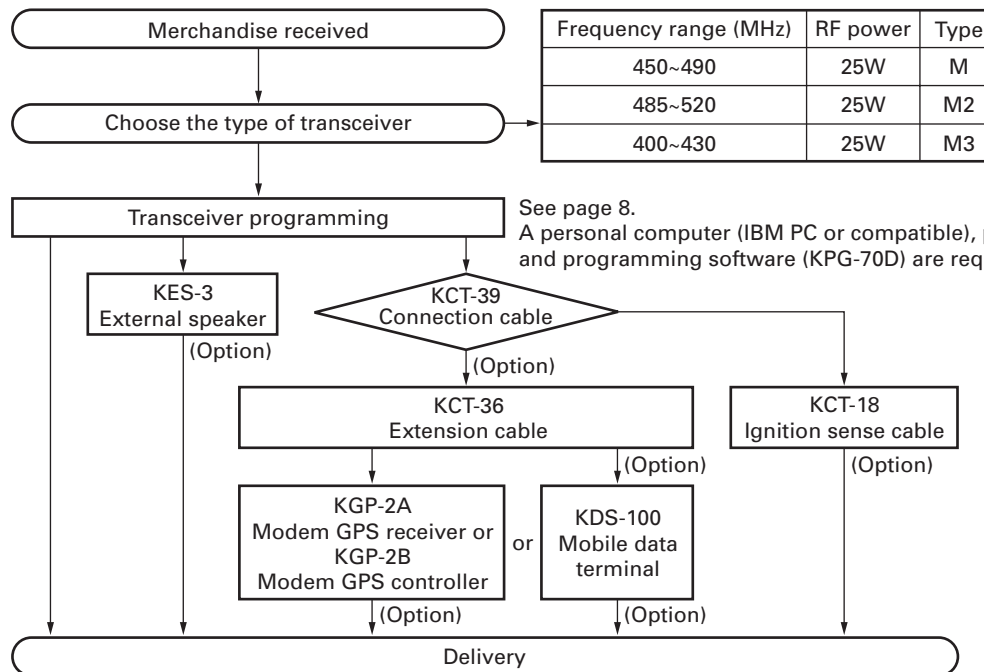

## OPERATING FEATURES

### 1. Controls and Functions

#### 1-1. Front Panel

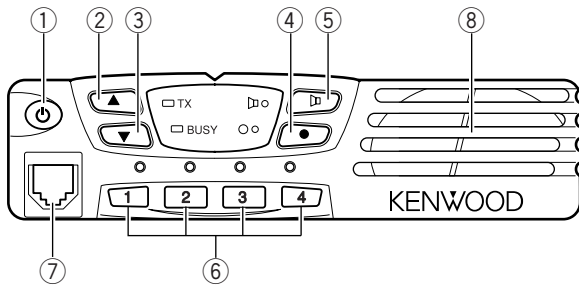

#### 1-2. Microphone

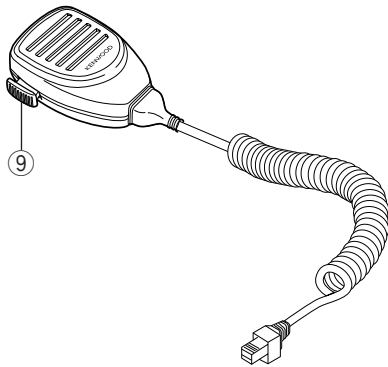

- ① **⏻ (Power) switch**  
Press to switch the transceiver ON. Press and hold for approximately 1 seconds to switch the transceiver OFF.
- ② **▲ key**  
Press to increase the volume level.
- ③ **▼ key**  
Press to decrease the volume level.
- ④ **● key**  
PF (Programmable Function) key. The default setting of this key is None (no function). The programmable functions available for this key are listed below.
- ⑤ **▶ key**  
PF (Programmable Function) key. The default setting of this key is Monitor. Other programmable functions available for this key are listed below.
- ⑥ **1/ 2/ 3/ 4 keys**  
Press to select a channel from 1 to 4.
- ⑦ **Microphone jack**  
Insert the microphone plug into this jack (the microphone is an optional accessory).
- ⑧ **Speaker**  
Internal speaker.
- ⑨ **PTT switch**  
Press this switch, then speak into the microphone to call a station.

#### 1-3. Auxiliary Programmable Functions

- Emergency
- Scan On/OFF
- Key Lock
- Talk Around
- Monitor
- Temporary Delete
- None (no function)
- AUX
- Horn Alert
- Scan + Temporary Delete

#### 1-4. Display

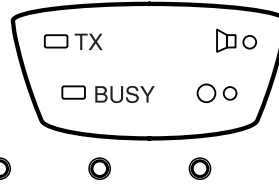

Indicator	Description
□ TX	Light while transmitting.
□ BUSY	Lights when a signal is detected on the currently selected channel.
▶○	Lights while the function programmed onto its corresponding key is activated.
○○	Lights while the function programmed onto its corresponding key is activated.
○ ○ ○ ○	Lights to display the currently selected channel (1~ 4).

#### 1-5. Rear panel

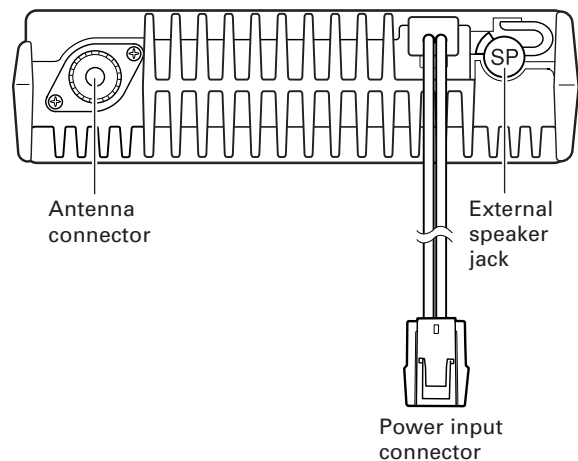

# OPERATING FEATURES

## 2. Operation Features

The TK-8102 is a UHF FM radio designed to operate in conventional format. The programmable features are summarized.

## 3. Transceiver Controls and Indicators

### 3-1. Front Panel Controls

All the keys on the front panel are momentary-type push buttons. The functions of these keys are explained below.

- **POWER key**

Transceiver POWER key. When the power is switched off, all the parameters are stored in memory. When the power is switched on again, the transceiver returns to the previous conditions.

- **CHANNEL keys**

- **MONITOR key (Programmable)**

- **● key (Programmable)**

- **VOLUME UP/DOWN key**

When the key is pressed, the volume level is increased/decreased and repeats if held for 200ms or longer.

- **BUSY/TX LED**

The BUSY indicator (Green LED) shows that the channel is in use. The TX indicator (Red LED) shows that you are transmitting.

### 3-2. Programmable Keys

The FPU (KPG-70D) enables programmable keys to select the following functions.

- Emergency
- Key Lock
- Monitor
- Scan ON/OFF
- Talk Around
- Temporary Delete
- None
- AUX
- Horn Alert
- Scan + Temporary Delete

- **Emergency**

Pressing this key for longer than 1 second causes the transceiver to enter the emergency mode. The transceiver jumps to the programmed "Emergency channel" and transmits for 25\* seconds.

The transceiver disables mic mute while transmitting. After finishing transmission, the transceiver receivers for 5\* seconds. The transceiver Mute\* the speaker while receiving. Following the above sequence, the transceiver continues to transmit and receive.

\* Default value.

- **Key lock**

Pressing this key causes the transceiver to accept entry of only the [Vol Up/Down]\*, [Key lock], Microphone [PTT], [Monitor], [Emergency], and [Power] keys.

\* Programmable

- **Monitor**

Used to release signalling (press once) or squelch (press and hold for approximately two seconds) when operating as a conventional. It is also used to reset option signalling.

- **Scan ON/OFF**

Press this key starts scanning. Pressing this key stops scanning.

- **Talk around**

Press this key, the transceiver uses the receive frequency and the tone for transmission.

The operator can call the other party directly (without repeater). Press this key again, the talk around function goes off.

- **Temporary delete**

The "Add" channel contained in the scan sequence, and "Delete" channel is not contained. In the scan mode, this key switches the channel delete temporarily (Press and hold for approximately one second).

When the transceiver is turned off, the transceiver exits the scan or switches the scan function off.

- **None**

Sounds error operation beep, and no action will occur. Use this function when the transceiver is required to be more simple operated.

- **AUX**

Press to activate the auxiliary port. Press again to deactivate the auxiliary port. Auxiliary is used with optional boards, allowing you to activate and deactivate these optional functions. While activated, the AUX icon appears on the display.

- **Horn alert**

Horn Alert is a useful feature that will notify you of a received call while you are away from your vehicle. The transceiver is programmed to sound the vehicle horn or some other external alert device (such as the vehicle headlights) when a call is received that has correct signalling.

- **Scan + Temporarily delete**

To temporarily remove a channel from the Scan list, press and hold this key for approximately one second during Scan, while Scan is paused on the undesired channel, to temporarily remove that channel from the scanning sequence. After switching the Scan function OFF, or switching the transceiver OFF and then ON again, the Scan settings return to normal

## OPERATING FEATURES

### 4. Scan Operating

#### ■ SCAN start condition

Two or more channels must be added to all channels that can be scanned. The transceiver must be in normal receive mode (PTT off).

When you activate the key programmed to the scan ON/OFF function, the scan starts. The indicator next to the programmed key LED blinks.

#### ■ Scan stop condition

The scan stops temporarily if the following conditions are satisfied.

- 1) A carrier is detected, then QT/DQT matches on channels for which receive the QT/DQT is set by the programming software.
- 2) A carrier is detected on the channels for which receiving QT/DQT is not set by the programming software or when the monitor (signalling cancel) function is activated.

#### ■ Revert channel

The revert channel is used to transmit during scanning and set by the programming software (KPG-70D).

- 1) Selected channel  
The transceiver reverts to the channel before scanning or the channel that you changed during scan.
- 2) Selected with talkback  
The transceiver reverts to the selected channel prior to scan initiation.  
However, if a call is received on a channel other than the selected channel and PTT is pressed before scanning resume, the transceiver "talks back" on the current receive channel.

#### ■ Scan end

When you press the key programmed to the scan function during scan mode, the scan ends.

The indicator next to the programmed key LED turns off.

#### ■ Temporary delete

It is possible to delete channel temporary during scan. When scan stops on unnecessary channel for example by interference of the other party, activate the delete function (for example press and hold the key for approximately one second), then that channel is deleted temporarily and scan restart immediately.

The temporary deleted channels return to pre-set delete/add channels, when the transceiver is turned off or the scan function is switched off.

### 5. Details of Features

#### ■ Time-out timer

The time-out timer can be programmed in 30 seconds increments from 30 seconds to five minutes and off. If the transmitter is transmitted continuously for longer than the programmed time, the transmitter is disabled and a warning tone sounds while the PTT button is held down. The warning tone stops when the PTT button is released.

#### ■ PTT ID

PTT ID provides a DTMF ANI or MSK ID to be sent with every time PTT (connect ID at beginning of transmission, disconnect ID at end of transmission, or both).

You can program PTT ID "on" or "off" for each group channel (DTMF). The contents of ID are programmed for each transceiver.

The transceiver is capable to have ID. The format is DTMF. The timing that the transceiver sends ID is programmable.

BOT : Connect ID is sent on beginning of transmission.

EOT : Disconnect ID is sent on end of transmission.

Both : Connect ID is sent on beginning of transmission and disconnect ID is sent on end of transmission.

There is also "PTT ID" setting for each channel.

#### ■ Off hook decode

If the Off hook decode function has been enabled, removing and replacing the microphone on the hook has no effect for decoding QT/DQT and option signalling.

#### ■ "TOT" pre-alert

The transceiver has "TOT" pre-alert timer. This parameter selects the time at which the transceiver generates "TOT" pre-alert tone before "TOT" is expired.

"TOT" will be expired when the selected time passes from a TOT pre-alert tone.

#### ■ "TOT" re-key time

The transceiver has "TOT" re-key timer. This timer is the time you can not transmit after "TOT" exceeded. After "TOT" re-key time expired you can transmit again.

#### ■ "TOT" reset time

The transceiver has "TOT" reset timer. This timer is the minimum wait time allowed during a transmission that will reset the "TOT" count.

"TOT" reset time causes the "TOT" to continue even after PTT is released unless the "TOT" reset timer has expired.

#### ■ Clear to transpond

The transceiver waits the transpond of DTMF if channel is busy until channel open. This feature prevents the interference to other party.

### 6. Option Signalling (DTMF)

Built-in DTMF decoder is available for option signalling.

It is possible to use individual call, group call, Stun.

If the option signalling matches, a predetermined action will occur.

If option signalling matches on a channel is set up with option signalling, the channel LED will flash and option signalling will be released. The transpond or alert tone will sound.

While option signalling matches (or if option signalling is deactivated when you are transmitting), you can mute or unmute QT/DQT/Carrier.



## OPERATING FEATURES

### ■ SP Unmute

You can select the type of SP Unmute system for each channel. The selection is as follows.

Carrier, QT/DQT:

Channel with this option will not check ID Code in order to open its speaker.

Carrier+DTMF, QT/DQT+DTMF:

Channel that is set with this option will have to check for ID Code in order to open its speaker.

Default:

Carrier, QT/DQT.

SP unmute	Channel setting		RX condition	Speaker condition
	QT/DQT	DTMF		
Carrier	None	None	Carrier	Sounds
		Yes	Carrier	Sounds
			Carrier+DTMF	Sounds
Carrier+DTMF	None	Yes	Carrier	Not Sounds
			Carrier+DTMF	Sounds
QT/DQT	Yes	None	Carrier	Not Sounds
			Carrier+QT/DQT	Sounds
		Yes	Carrier	Not Sounds
			Carrier+QT/DQT	Sounds
			Carrier+QT/DQT+DTMF	Sounds
Carrier+DTMF	Not Sounds			
QT/DQT+DTMF	Yes	Yes	Carrier	Not Sounds
			Carrier+QT/DQT	Not Sounds
			Carrier+QT/DQT+DTMF	Sounds
			Carrier+DTMF	Not Sounds

### Note :

When QT/DQT is not used, QT/DQT and QT/DQT+DTMF can not be selected.

When DTMF is not used, Carrier+DTMF and QT/DQT+DTMF can not be selected.

### ■ Auto Reset

If option signalling matches a group set up with option signalling, option signalling is released. After matching option signalling, option signalling will temporarily reset automatically.

### ■ Stun

If the stun code matches, a predetermined action will occur. Whether option signalling is activated or not, when stun matches on any channel, the transceiver will become TX inhibited or TX/RX inhibited. While stun is active, if the stun code + “#” code is received, stun will deactivate.

When stun matches, transpond will function. Alert will not be output.

## 7. Audible User Feedback Tones

The transceiver outputs various combinations of tones to notify the user of the transceiver operating state.

Refer to the help file on the KPG-70D, regarding the functions that are not listed below.

### ■ Stun on tone

When a stun code is received, transpond tone sounds.

### ■ Stun off tone

When a stun release code is received, transpond tone sounds.

### ■ Group call tone

Sounds when a group call with the correct DTMF option signalling is received, repeats 7 times. You can select yes or no in the Alert tone level setting.

### ■ Individual call tone

Sounds when an individual call with the correct DTMF option signalling is received. You can select yes or no in the Alert tone level setting.

### ■ Key input error tone

Sounds when a key is pressed but that key cannot be used. You can select yes or no for the optional feature's warning tone.

### ■ Transpond tone

Sounds when an individual call with the correct DTMF option signalling is received. For group calls, only the group tone will sound, not the transpond tone.

### ■ Pre alert tone

Sounds prior to the TOT TX inhibit activation. If TOT pre alert is set, the tone sounds at the amount of time programmed, before the TOT expires (TOT time – TOT pre alert time = Pre alert tone sounding time). You can select yes or no for the optional feature's warning tone.

### ■ Transmit protection

The power module is protected against heat while transmitting by making the radio cuts down TX power when the temperature of the power module becomes higher than reference. After that, if the temperature continue to rise, transmission is stopped. The power module is also protected against over voltage by having the radio to check that the voltage of power supply connected to the radio is not higher than about 17V when the radio is turned on, otherwise it can not transmit. In both cases when transmission is stopped, a beep will continue to sound until the PTT key is released.



## REALIGNMENT

### 1. Modes

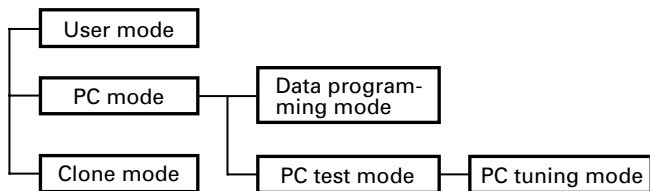

Mode	Function
User mode	For normal use.
PC mode	Used for communication between the radio and PC (IBM compatible).
Data programming mode	Used to read and write frequency data and other features to and from the radio.
PC test mode	Used to check the radio using the PC. This feature is included in the FPU.
PC tuning mode	Used to tune the radio using the PC.
Clone mode	Used to transfer programming data from one radio to another.

### 2. How to Enter Each Mode

Mode	Operation
User mode	Power ON
PC mode	Received commands from PC
Clone mode	[1]+Power ON (Two seconds)

### 3. PC Mode

#### 3-1. Preface

The TK-8102 transceiver is programmed using a personal computer, a programming interface (KPG-46) and programming software (KPG-70D).

The programming software can be used with an IBM PC or compatible. Figure 1 shows the setup of an IBM PC for programming.

#### 3-2. Connection Procedure

1. Connect the TK-8102 to the personal computer with the interface cable.
2. When the Power is switched on, user mode can be entered immediately. When the PC sends a command, the radio enters PC mode. When data is transmitted from transceiver, the red LED blink. When data is received by the transceiver, the green LED blink. In the PC mode, 4CH LEDs, [MON] LED and [●] LED are turned on.

#### Notes :

- The data stored in the personal computer must match model type when it is written into the EEPROM.
- Attach the interface cable, then change the TK-8102 to PC mode.

#### 3-3. KPG-46 Description

##### (PC programming interface cable : Option)

The KPG-46 is required to interface the TK-8102 to the computer. It has a circuit in its D-subconnector (25-pin) case that converts the RS-232C logic level to the TTL level.

The KPG-46 connects the modular microphone jack of the TK-8102 to the computers RS-232C serial port.

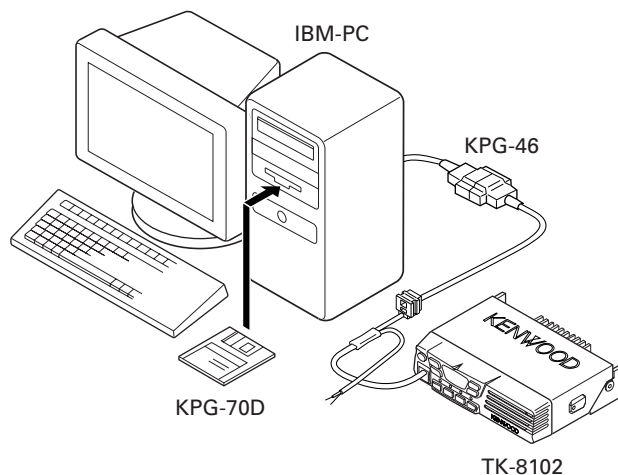

Fig. 1

#### 3-4. Programming Software Description

The KPG-70D programming disk is supplied in 3-1/2" disk format. The software on this disk allows a user to program TK-8102 radio via a programming interface cable (KPG-46).

#### 3-5. Programming With IBM PC

If data is transferred to the transceiver from an IBM PC with the KPG-70D, the destination data (basic radio information) for each set can be modified.

## REALIGNMENT

### 4. Clone Mode

Programming data can be transferred from one radio to another by connecting them via their modular microphone jacks. The operation is as follows (the transmit radio is the master and the receive radio is the slave).

#### Note :

Clone mode should be enabled.

1. Turn the master TK-8102 power ON with the [1] key held down. The TK-8102 [●] LED is turned on.
2. Power on the slave TK-8102H.
3. Connect the cloning cable (No. E30-3382-05) to the modular microphone jacks on the master and slave.
4. Press the [●] key on the master TK-8102 transceiver. The data of the master is sent to the slave. While the master is sending data, [TX] LED blinked. While the slave is receiving the data, 4 LEDs, [MON] LED, [●] LED are turned on and [BUSY] LED blinked. When cloning of data is completed, the master [TX] LED turned off, and the slave automatically operates in the User mode. The slave can then be operated by the same program as the master.
5. The other slave can be continuously cloned. Carry out the operation in step 2 to 4.

#### 4-1. Adding the data password.

If the data password is set in the optional feature menu, you must enter the password (Master transceiver) to activate a clone mode.

you can use 1, 2, 3, and 4 to configure the password. The maximum length of the password is 10 digits.

1. [1]+Power ON.
2. [1]~[4] LED, and MON LED are turned ON.
3. Enter the password using [1]~[4] keys.
4. Press [MON] key.
5. If the password matches, the transceiver enters a clone mode. Otherwise, transceiver beeps and returns to the password input mode.

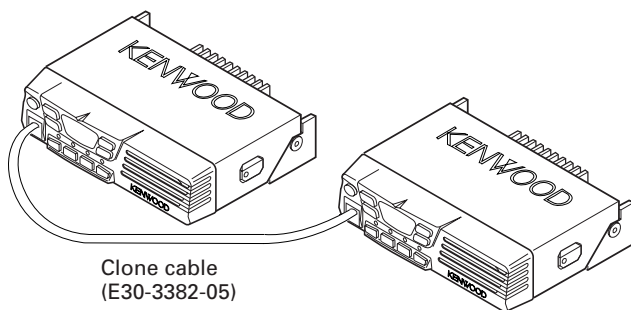
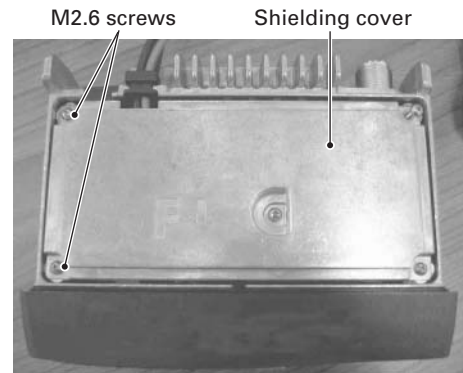

Fig. 2

### 5. Accessory Connection Cable (KCT-39)

The KCT-39 is an accessory connection cable for connecting external equipment. The connector has 15 pins and the necessary signal lines are selected for use.

1. Unscrew the five M2.6 screws (N87-2614 -46), then remove the shielding cover (F10-2491-03).



2. Lift the DC cord (E30 -3448 -05) and remove the cushion (G13 -2003 -04) from the chassis.

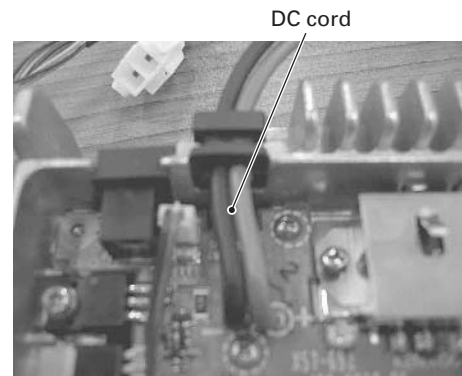

3. Attach a new cushion (G13-1960 -08) to the DC bush.

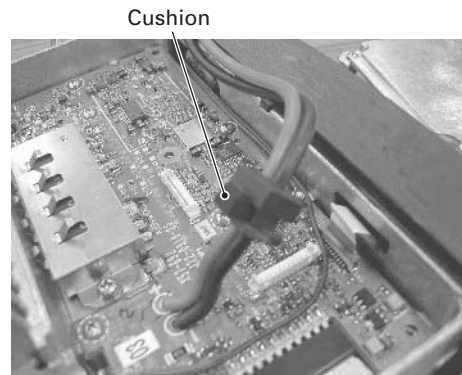

## REALIGNMENT

4. Place the KCT-39 sumi tube along the chassis and insert the cable tie into the TX-RX PCB slot, as shown in the diagram below.

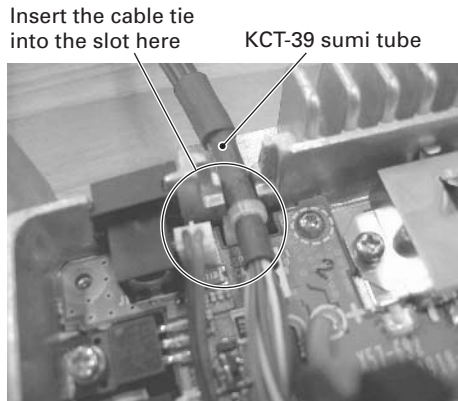

5. Align the KCT -39 cable to the left side of the DC cord, then place the DC cord back into its slot along the chassis (over the top of the KCT-39 sumi tube).



6. Twist the large grouping of wires of the KCT-39 cable twice, then connect it to Terminal A of the PCB. Connect the remaining grouping of wires of the KCT -39 cable to Terminal B.

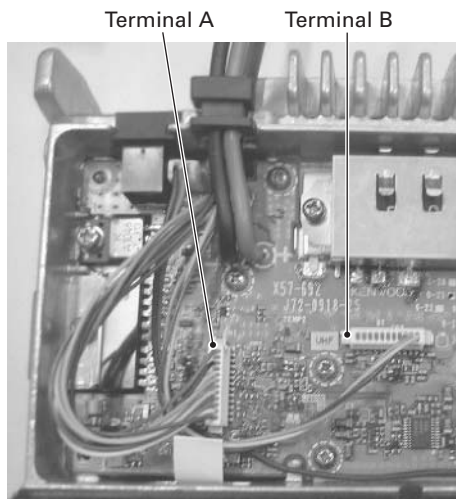

7. Align the terminal B KCT -39 cable underneath the terminal A cable align the speaker cable (T07 -1082 -05) below both KCT-39 cables.

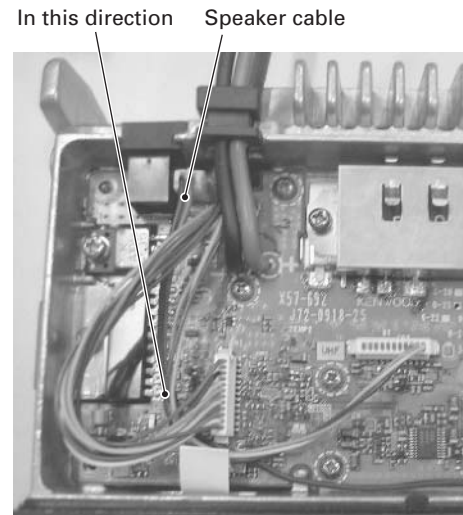

8. Align all cable to the left side so as to avoid the Power Module Area. Mount the shielding cover and secure it with the five M2.6 screws.

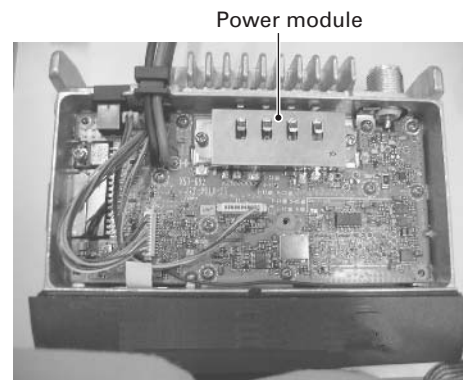

9. After everything has been properly mounted, the KCT-39 sumi tube should look similar to that as shown in the diagram below.



## REALIGNMENT

10. Connect the KCT-39 to the external accessory by inserting the crimp terminal ( ❶ ) into the square plug ( ❷ ), both of which are supplied with the KCT-39.

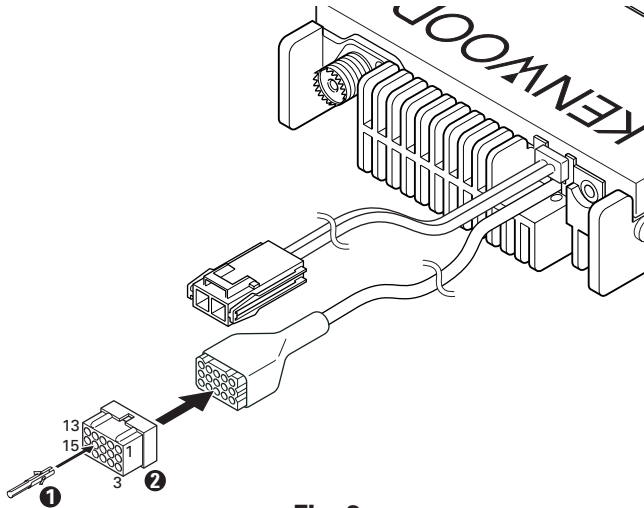
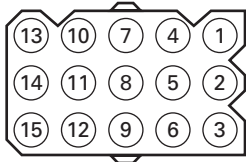

Fig. 3

### ■ Accessory Port Function



No.	Color	Internal connector	Name
1	Red	CN2-1	SB
2	Pink	CN3-1	IGN
3	Black	CN2-3	GND
4	Brown	CN3-3	DETO
5	Orange	CN3-2	DATAI
6	Yellow	CN2-8	FNC4
7	Green	CN2-7	FNC3
8	Blue	CN2-9	FNC5
9	Purple	CN2-12	FNC8
10	Gray	CN2-10	FNC6
11	White	CN2-11	FNC7
12	NC	NC	
13	NC	NC	
14	Sky blue	CN2-6	FNC2
15	Turquoise	CN2-5	FNC1

### 6. Ignition Sense Cable (KCT-18)

The KCT-18 is an optional cable for enabling the ignition function. The ignition function lets you turn the power to the transceiver on and off with the car ignition key.

#### 6-2. Connecting the KCT-18 to the Transceiver

1. Install the KCT-39 in the transceiver. (See the KCT-39 section)
2. Insert the KCT-18 lead terminal ( ❶ ) into pin 2 of the KCT-39 ( ❷ ).

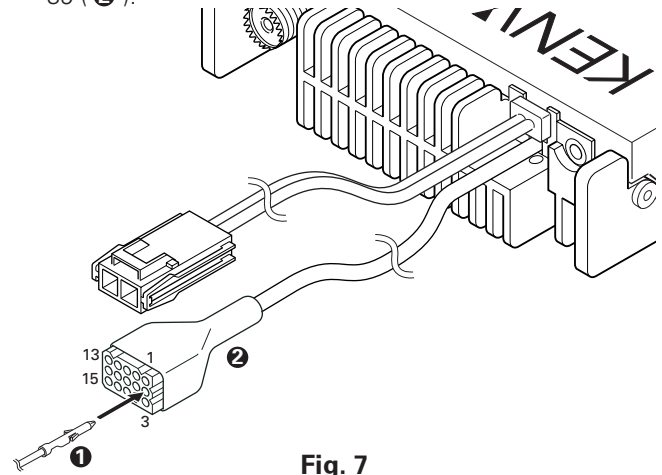

Fig. 7

#### 6-3. Modifying the Transceiver

Modify the transceiver as follows to turn the power on and off with the ignition key.

1. Remove the resistor R71 of the TX-RX unit.

#### ■ Setting With the KPG-70D

Select "External Devices" from the "Edit" menu and enable the "Ignition Sense".

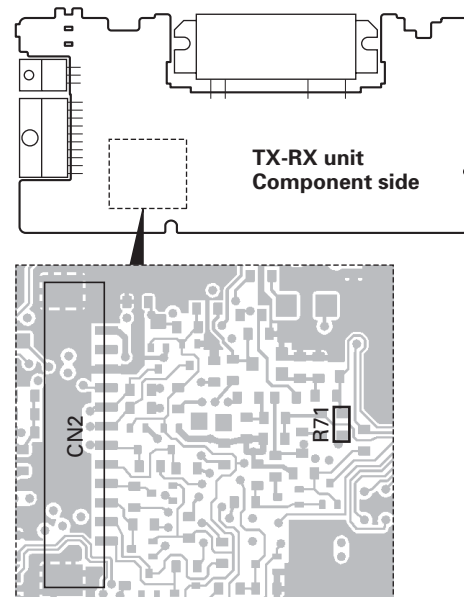

Fig. 8

## INSTALLATION

### 1. Optional Board

#### 1-1. Voice Scrambler Board Connection

##### ■ Modification

1. Remove the cabinet and shielding cover from the transceiver.
2. Delete R202 and R267 on the TX-RX unit.

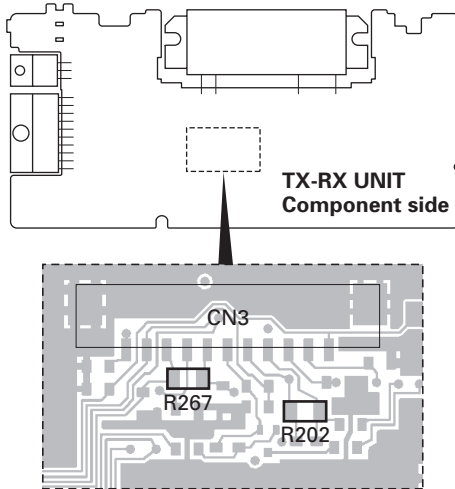

Fig. 1

##### ■ Connection

The functions of pins of CN2 and CN3 on the TX-RX unit are shown in the TERMINAL FUNCTION section (page 37).

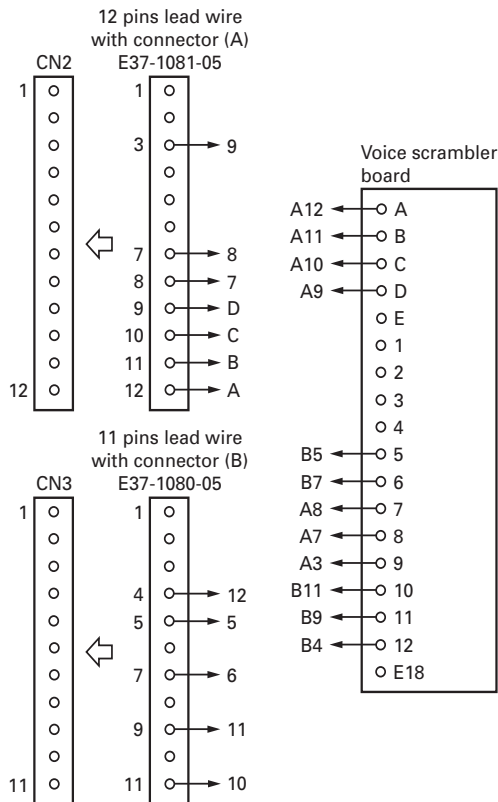

Fig. 2

##### ■ Pins Connection

Voice scrambler functions	12 pins lead wire with connector (A)	11 pins lead wire with connector (B)
A	A-12	–
B	A-11	–
C	A-10	–
D	A-9	–
5	–	B-5
6	–	B-7
7	A-8	–
8	A-7	–
9	A-3	–
10	–	B-11
11	–	B-9
12	–	B-4

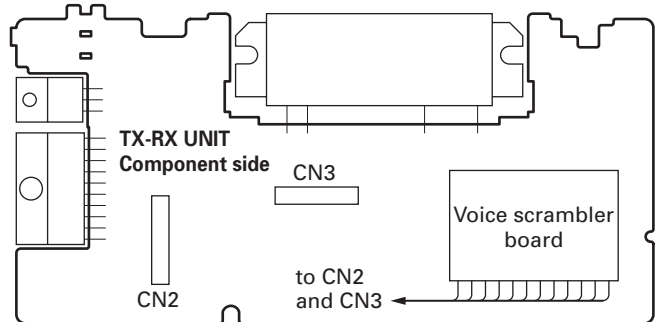

Fig. 3

##### ■ Setting With the KPG-70D

Select "External Devices" from the "Edit" menu and set the "Scrambler".

##### Note :

The voice scrambler board is connected subsequent to the de-emphasis circuit.



## INSTALLATION

### 2. SmarTrunk

1. Unscrew the five M2.6 screws (N87-2614 -46), then remove the shielding cover (F10-2491-03).

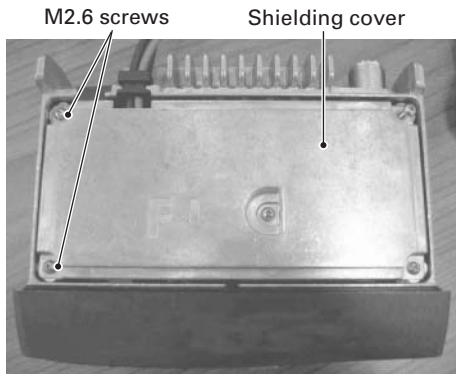

2. The SmarTrunk Board is to be mounted in the silk-screened area.

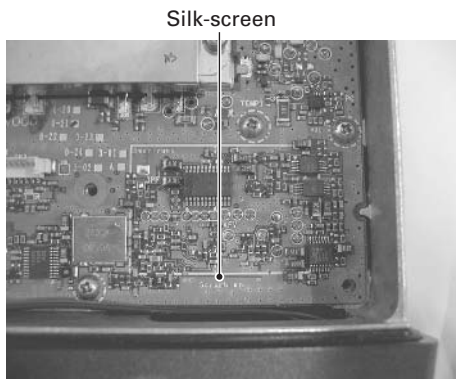

3. Adhere one side of the 27 x 17.5 x 1mm cushion G (G13-2005 -04) to the underside of the ST-909.

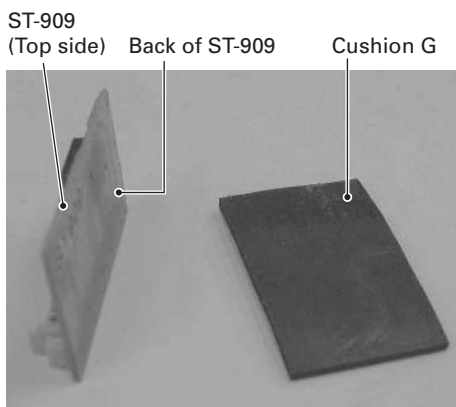

4. Connect the cable (E37 -1117 -05) to the topside of the ST-909.

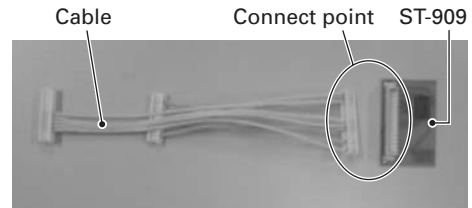

5. Mount the ST-909 onto the TX-RX PCB using the adhesive cushion on the underside of the ST-909, onto the left edge of the silk-screen area. Connect the cables to the two terminals.

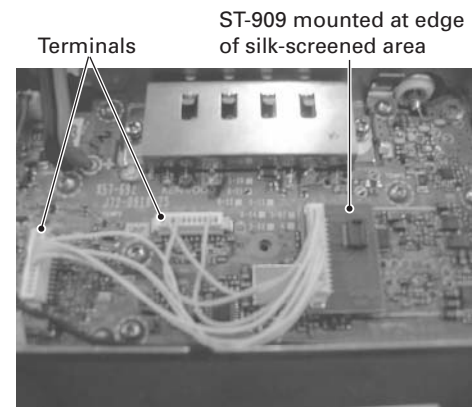

6. Adhere the 13 x 9 x 8 mm cushion F (G13-2006-04) to the top side of the ST-865KW4, between the variable resistor (R18) and the capacitor (C19), then place the supplied insulation sheet over the integrated circuit (IC).

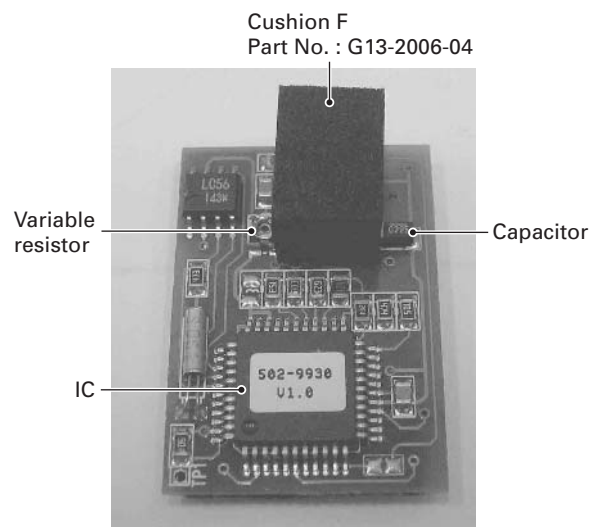

## INSTALLATION

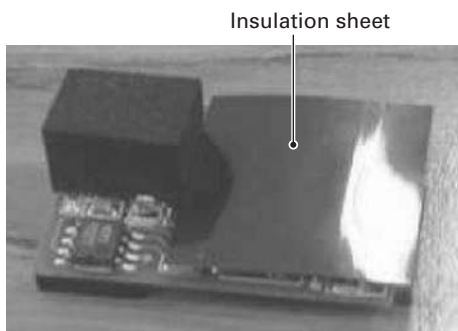

7. Adhere the 10 x 10 x 2.5 mm cushion E (G13-2007 -04) and the supplied 20 x 20 x 1mm cushion C to the underside of the ST-865KW4 as shown in the diagram below.

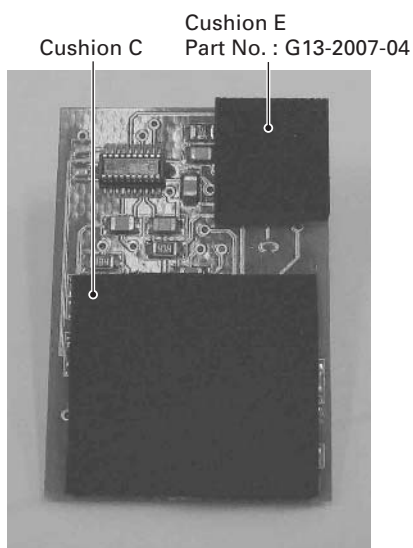

### Note :

- For the SmarTrunk option, cushion C and the insulation sheet are included in the package.
- For TK-7102 & TK-8102 series, cushion A is not used. Cushion A is replaced by cushion F.
- Cushion B is replaced by cushion E.

8. Align the connector on the underside of the ST-865KW4 with the connector on the top side of the ST-909, then press down on cushion E to secure them.

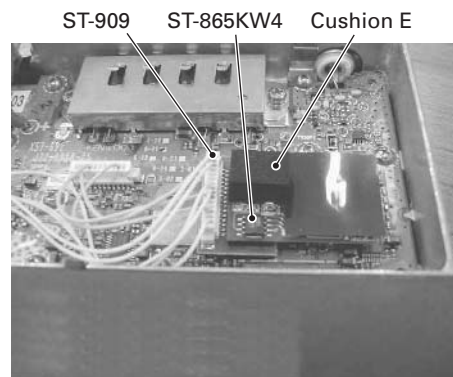

9. Flatten the cable so as to avoid potential damage when mounting the shielding cover. Mount the shielding cover and secure it with the five M2.6 screws.

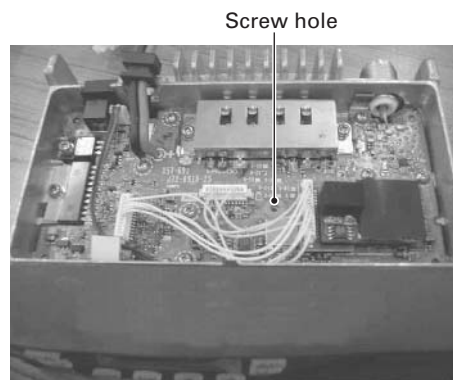

### Note :

- ST-909 and ST-865KW4 are available from SmarTrunk Systems, Inc.

### ■ Setting With the KPG-70D

Select "External Devices" from the "Edit" menu and set the "SmarTrunk".



## DISASSEMBLY FOR REPAIR

1. When you remove the panel, turn the transceiver up side down. Detach the panel by lifting the tabs as shown below.

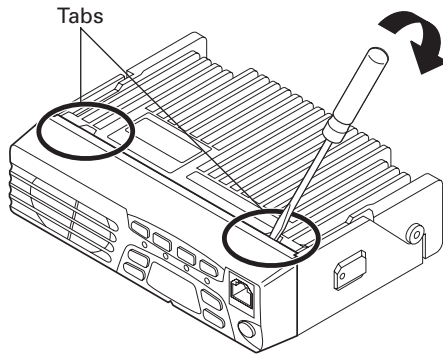

**Fig. 1**

2. To remove the cabinet, first turn the transceiver up side down. Detach the cabinet by prying the tabs as shown below.

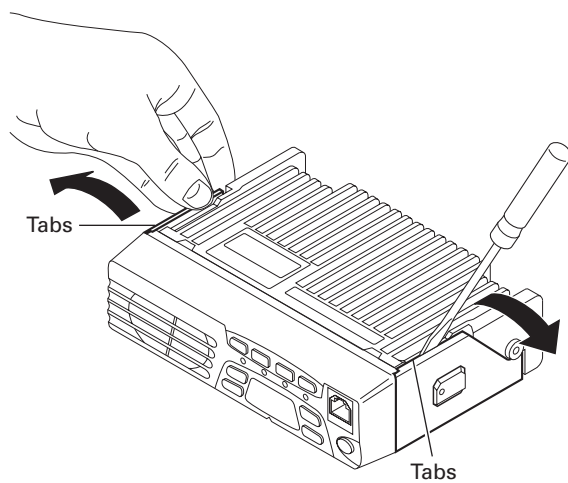

**Fig. 2**

3. To remove the display unit PCB, detach the PCB by lifting at the indents of the PCB as shown below.

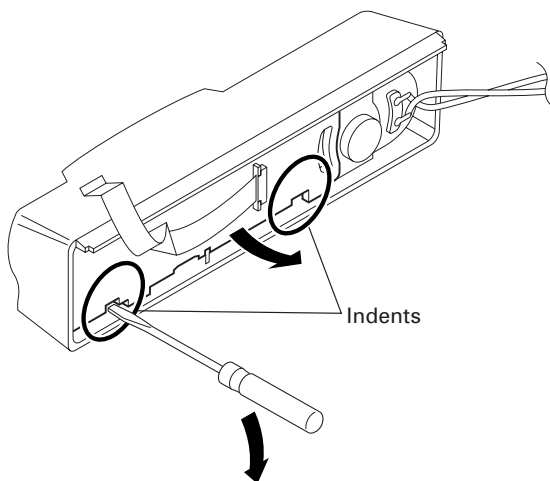

**Fig. 3**

4. Mount the display unit  
To mount the display unit on the panel, follow the correct procedures shown to ensure easy display unit assembly and good fitting onto the panel.

- ① Snap in bottom of display unit first.
- ② Snap in top of display unit.

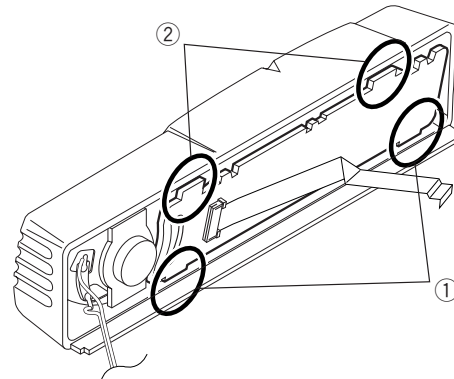

**Fig. 4**

5. When mounting the front panel, match the 4 tabs of the chassis with the panel, being sure they attach securely.

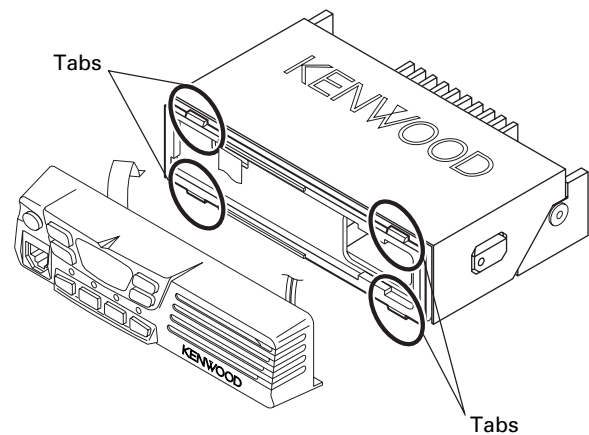

**Fig. 5**

## CIRCUIT DESCRIPTION

### Frequency Configuration

The receiver utilizes double conversion. The first IF is 49.95MHz and the second IF is 450kHz. The first local oscillator signal is supplied from the PLL circuit.

The PLL circuit in the transmitter generates the necessary frequencies. Figure 1 shows the frequencies.

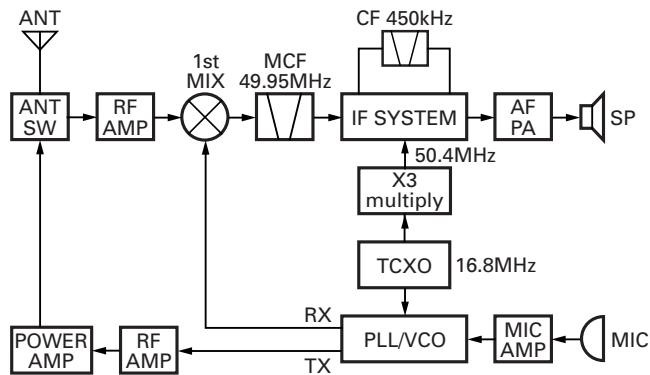

Fig. 1 Frequency configuration

### Receiver System

The receiver is double conversion superheterodyne. The frequency configuration is shown in Figure 1.

#### ■ Front-end RF Amplifier

An incoming signal from the antenna is applied to an RF amplifier (Q353) after passing through a transmit/receive switch circuit (D604 and D605 are off) and a BPF (L359, L358, L360, L361 and varactor diodes : D353, D354, D355). After the signal is amplified (Q353), the signal is filtered by a BPF (L354, L355 and varactor diodes: D351, D352) to eliminate unwanted signals before it is passed to the first mixer.

The voltage of these diodes are controlled by tracking the CPU (IC101) center frequency of the band pass filter. (See Fig. 2)

#### ■ First Mixer

The signal from the RF amplifier is heterodyned with the first local oscillator signal from the PLL frequency synthesizer circuit at the first mixer (Q352) to create a 49.95MHz first intermediate frequency (1st IF) signal. The first IF signal is then fed through one pair of monolithic crystal filter (MCF : XF351) to further remove spurious signals.

#### ■ IF Amplifier

The first IF signal is amplified by Q351, and the enters IC301 (FM processing IC). The signal is heterodyned again with a second local oscillator signal within IC301 to create a 450kHz second IF signal. The second IF signal is then fed through a 450kHz ceramic filter (Wide : CF301, Narrow : CF302) to further eliminate unwanted signals before it is amplified and FM detected in IC301.

Item	Rating
Nominal center frequency	49.95MHz
Pass bandwidth	±5.0kHz or more at 3dB
35dB stop bandwidth	±20.0kHz or less
Ripple	1.0dB or less
Insertion loss	5.0dB or less
Guaranteed attenuation	80dB or more at fo±1MHz Spurious : 40dB or more within fo±1MHz
Terminal impedance	350Ω / 5.5pF

Table 1 Crystal filter (L71-0591-05) : XF351

Item	Rating
Nominal center frequency	450kHz
6dB bandwidth	±6.0kHz or more
50dB bandwidth	±12.5kHz or less
Ripple	2.0dB or less
Insertion loss	6.0dB or less
Guaranteed attenuation	35.0dB or more within fo±100kHz
Terminal impedance	2.0kΩ

Table 2 Ceramic filter (L72-0993-05) : CF301

Item	Rating
Nominal center frequency	450kHz
6dB bandwidth	±4.5kHz or more
50dB bandwidth	±10.0kHz or less
Ripple	2.0dB or less
Insertion loss	6.0dB or less
Guaranteed attenuation	60.0dB or more within fo±100kHz
Terminal impedance	2.0kΩ

Table 3 Ceramic filter (L72-0999-05) : CF302

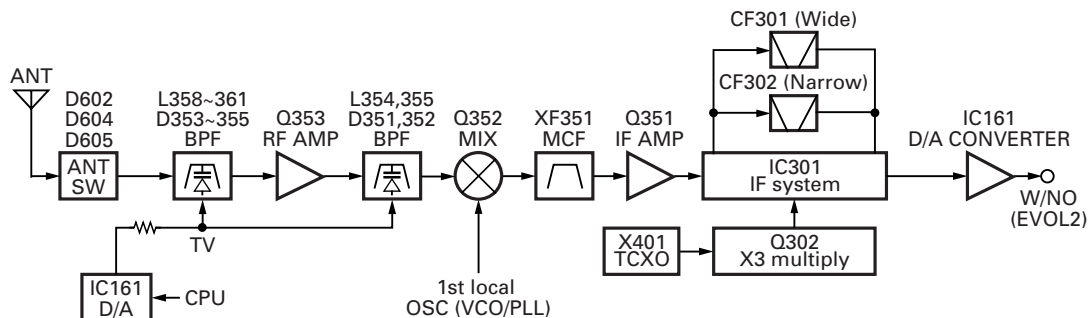

Fig. 2 Receiver system

## CIRCUIT DESCRIPTION

### Wide/Narrow Switching Circuit

The Wide port (pin 65) and Narrow port (pin 64) of the CPU is used to switch between ceramic filters. When the Wide port is high, the ceramic filter SW diodes (D303, D302) cause CF301 to turn on to receive a Wide signal.

When the Narrow port is high, the ceramic filter SW diodes (D303, D302) cause CF302 to turn on to receive a Narrow signal.

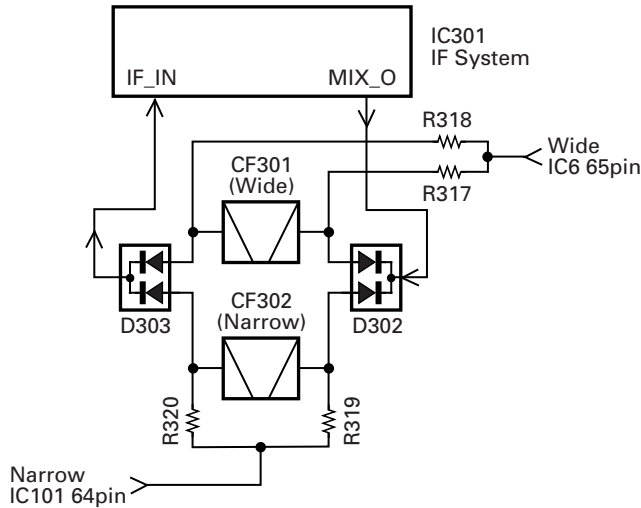

Fig. 3 Wide/Narrow switching circuit

### AF Signal System

The detection signal from IF IC (IC301) goes to D/A converter (IC161) to adjust the gain and is output to AF filter (IC251) for characterizing the signal. The AF signal output from IC251 and the DTMF signal, BEEP signal are summed and the resulting signal goes to the D/A converter (IC161). The AFO output level is adjusted by the D/A converter. The signal output from the D/A converter is input to the audio power amplifier (IC252). The AF signal from IC252 switches between the internal speaker and speaker jack (J1) output.

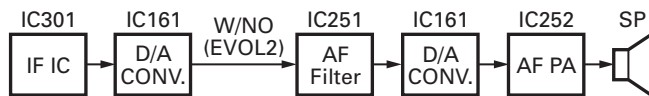

Fig. 4 AF signal system

### Squelch Circuit

The detection output from the FM IF IC (IC301) passes through a noise amplifier (Q301) to detect noise. A voltage is applied to the CPU (IC101). The CPU controls squelch according to the voltage (SQIN) level. The signal from the RSSI pin of IC301 is monitored. The electric field strength of the receive signal can be known before the SQIN voltage is input to the CPU, and the scan stop speed is improved.

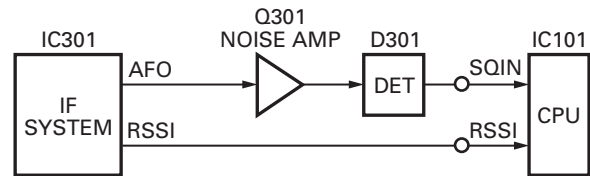

Fig. 5 Squelch circuit

### PLL Frequency Synthesizer

The PLL circuit generates the first local oscillator signal for reception and the RF signal for transmission.

#### PLL

The frequency step of the PLL circuit is 5 or 6.25kHz. A 16.8MHz reference oscillator signal is divided at IC401 by a fixed counter to produce the 5 or 6.25kHz reference frequency. The voltage controlled oscillator (VCO) output signal is buffer amplified by Q410, then divided in IC401 by a dual-module programmable counter. The divided signal is compared in phase with the 5 or 6.25kHz reference signal in the phase comparator in IC401. The output signal from the phase comparator is filtered through a low-pass filter and passed to the VCO to control the oscillator frequency. (See Fig. 6)

#### VCO

The operating frequency is generated by Q406 in transmit mode and Q405 in receive mode. The oscillator frequency is controlled by applying the VCO control voltage, obtained from the phase comparator, to the varactor diodes (D405 and D406 in transmit mode and D403 and D404 in receive mode). The TX/RX pin is set low in receive mode causing Q408 and Q407 to turn Q406 off, and turn Q405 on. The TX/RX pin is set high in transmit mode. The outputs from Q405 and Q406 are amplified by Q410 and sent to the RF amplifiers.

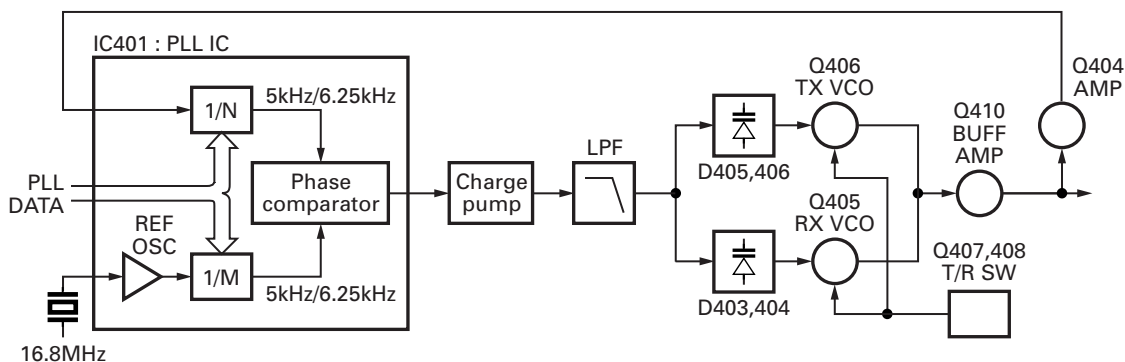

Fig. 6 PLL circuit

## CIRCUIT DESCRIPTION

### ■ Unlock Circuit

During reception, the 8RC signal goes high, the 8TC signal goes low, and Q34 turns on. Q33 turns on and a voltage is applied to the collector (8R). During transmission, the 8RC signal goes low, the 8TC signal goes high and Q36 turns on. Q35 turns on and a voltage is applied to 8T.

The CPU in the control unit monitors the PLL (IC401) LD signal directly. When the PLL is unlocked during transmission, the PLL LD signal goes low. The CPU detects this signal and makes the 8TC signal low. When the 8TC signal goes low, no voltage is applied to 8T, and no signal is transmitted.

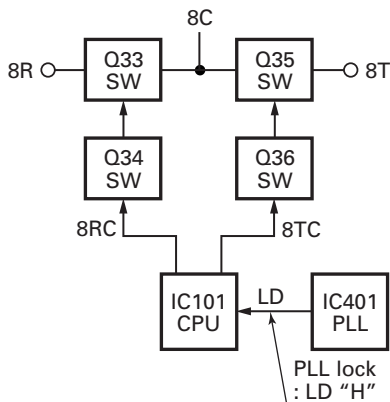

Fig. 7 Unlock circuit

### Transmitter System

#### ■ Outline

The transmitter circuit produces and amplifies the desired frequency directly. It FM-modulates the carrier signal by means of a varicap diode.

#### ■ Power Amplifier Circuit

The transmit output signal from the VCO passes through the transmission/reception selection diode (D409) and amplified by Q500, Q501 and Q502. The amplified signal goes to the power amplifier (IC502) through a low-pass filter. The low-pass filter removes unwanted high-frequency harmonic components, and the resulting signal is goes the antenna terminal.

#### ■ APC Circuit

The automatic transmission power control (APC) circuit detects the power amplifier (IC502) output with a diode (D606, D607) and applies a voltage to IC501. IC501 compares the APC control voltage (PC) generated by the D/A converter (IC161) and DC amplifier (IC203) with the detection output voltage. IC501 generates the voltage to control IC502 and stabilizes transmission output.

The APC circuit is configured to protect over current of IC502 due to fluctuations of the load at the antenna end and to stabilize transmission output at voltage and temperature variations.

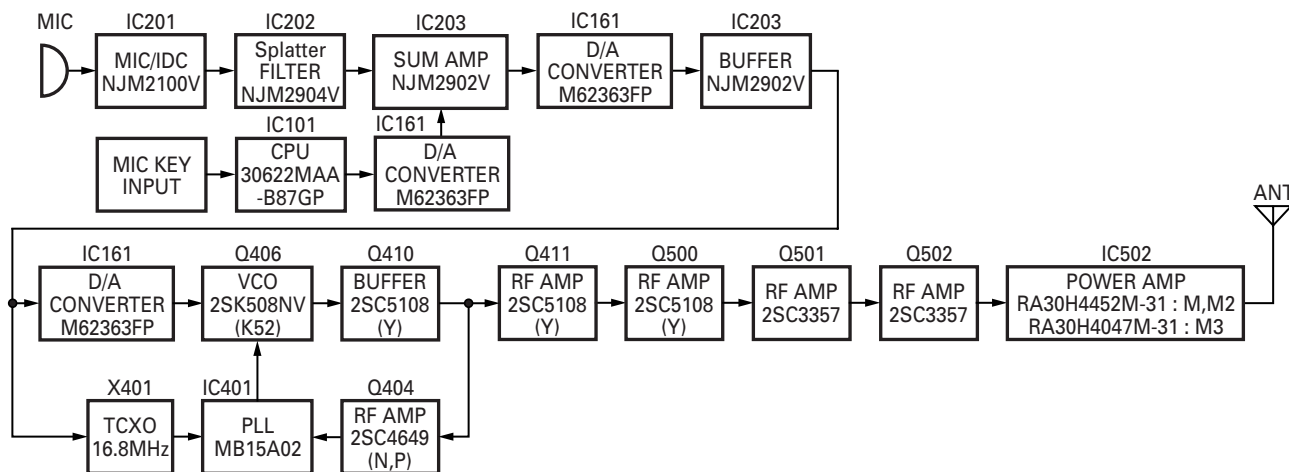

Fig. 8 Transmitter system

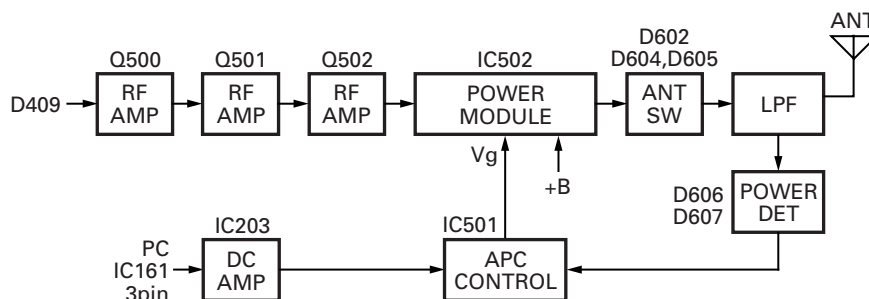

Fig. 9 APC circuit

## CIRCUIT DESCRIPTION

### Control Circuit

The CPU carries out the following tasks:

- 1) Controls the WIDE, NARROW, TX/RX outputs.
- 2) Adjusts the AF signal level of the AF filter (IC251) and turns the filter select compounder on or off.
- 3) Controls the display unit.
- 4) Controls the PLL (IC401).
- 5) Controls the D/A converter (IC161) and adjusts the volume, modulation and transmission power.

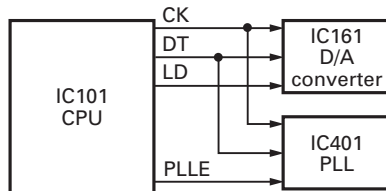

Fig. 10 Control circuit

### Memory Circuit

The transceiver has a 64k-bit EEPROM (IC66). The EEPROM contains adjustment data. The CPU (IC101) controls the EEPROM through three serial data lines.

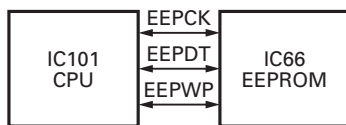

Fig. 11 Memory circuit

### Display Circuit

The shift register controls the display LEDs through the CL and DI lines from the CPU (IC101).

When the transceiver is busy, LED G line becomes high impedance, turning on Q4 and the green LED (D11) lights, in transmit mode, the LED R line becomes low impedance, and the red LED (D12) lights.

Backlit LEDs (D1~D4) are provided and will only go on when MBL line becomes low impedance.

When a function key (MON, PF, C1, C2, C3 or C4) is selected, its respective line becomes low impedance (LED MON, LED PF, LED C1, LED C2, LED C3 or LED C4), the amber LED lights.

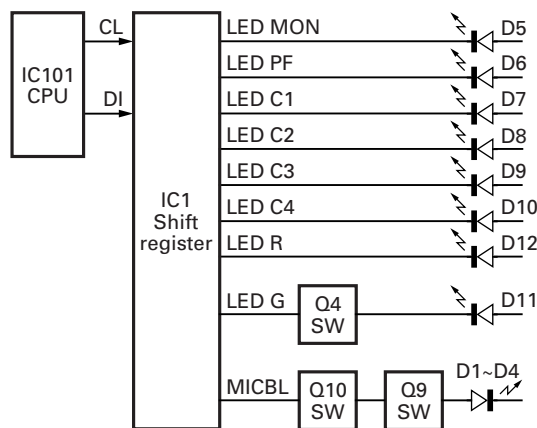

Fig. 12 Display circuit

### Key Matrix Circuit

The TK-8102 front panel has function keys. Each of them is connected to a cross point of a matrix of the KMI1 to KMO2 ports of the microprocessor. The KMO1 to KMO2 ports are always high, while the KMI1 to KMI4 ports are always low.

The microprocessor monitors the status of the KMI1 to KMO2 ports. If the state of one of the ports changes, the microprocessor assumes that the key at the matrix point corresponding to that port has been pressed.

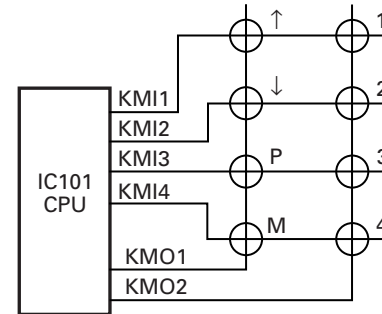

Fig. 13 Key matrix circuit

### Encode

The QT and DQT signals are output from QT/DQT of the CPU (IC101) and summed with the external pin DI line by the summing amplifier (IC203) and the resulting signal goes to the D/A converter (IC161). The DTMF signal is output from DTMF of the CPU and goes to the D/A converter (IC161). The signal is summed with a MIC signal by the summing amplifier (IC203), and the resulting signal goes to the D/A converter (IC161).

The D/A converter (IC161) adjusts the MO level and the balance between the MO and QT/DQT levels. Part of a QT/DQT signal is summed with MO and the resulting signal goes to the VCOMOD pin of the VCO. This signal is applied to a varicap diode in the VCO for direct FM modulation.

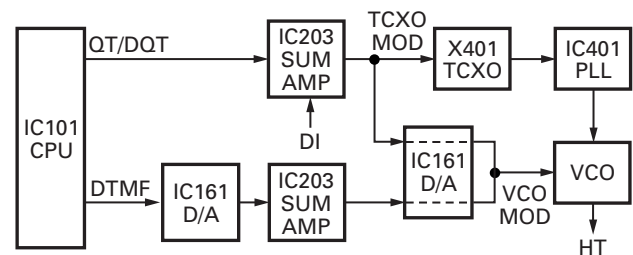

Fig. 14 Encode

## CIRCUIT DESCRIPTION

### ■ Decode

#### • QT/DQT/DTMF

The signal (W/NO (EVOL2)) goes to SIGNAL (pin 88) of CPU (IC101). The QT/DQT signal will pass through the low-pass filters in the CPU (IC101) and be decoded within the CPU (IC101). The DTMF signal will be decoded within the CPU (IC101).

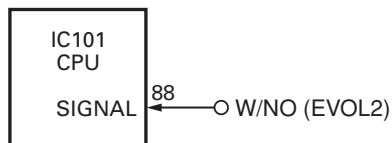

Fig. 15 Decode

### ■ D/A Converter

The D/A converter (IC161) is used to adjust MO modulation, AF volume, TV voltage, FC reference voltage, and PC POWER CONTROL voltage level.

Adjustment values are sent from the CPU as serial data. The D/A converter has a resolution of 256 and the following relationship is valid:

$$\text{D/A output} = (\text{Vin} - \text{VDAREF}) / 256 \times n + \text{VDAREF}$$

Vin: Analog input

VDAREF: D/A reference voltage

n: Serial data value from the microprocessor (CPU)

### Power Supply Circuit

When the power switch on the display unit is pressed, the power port on the display unit which is connected port 17 (POWER), goes low, then port 82 (SBC) goes high, Q32 turns on, SB SW (Q31) turns on and power (SB) is supplied to the radio.

When the DC power supplied to the radio, the voltage regulator IC (IC33) supply into the CPU VDD and reset voltage detect IC (IC34). IC34 will generate signal (RESET) in to the reset terminal on the CPU (IC101) to carry out a power ON reset. Also, CPU (IC101) is checking on port 91 (Battery Voltage). If DC power is less than about 9.5V, the radio is unable to power on.

When the DC power voltage decreases from normal voltage, the INT voltage detector IC (IC35) will set to high on CPU port 18 (INT) if B line will became less than about 9.5V. Then CPU send to EEPROM (IC66) the backup data and go into STOP mode.

This circuit has an overvoltage protection circuit. If a DC voltage of 18V or higher is applied to the base of Q61, this voltage turns Q61 on and turns Q32 and SB off.

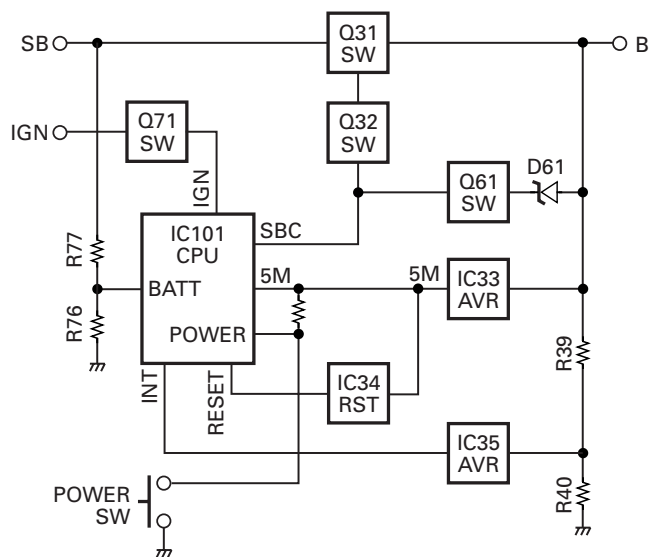

Fig. 16 Power supply circuit

## SEMICONDUCTOR DATA

## Microprocessor : 30622MAA-B87GP (TX-RX Unit IC101)

## ■ Terminal Function

Pin No.	Name	I/O	Function
1	QT/DQT	O	QT/DQT output.
2	DTMF/MSK	O	DTMF/MSK/BEEP output
3	PLLE	O	PLL IC chip select.
4,5	NC	I	
6	GND	-	GND.
7	CNVSS	-	CNVss for flash.
8	EVLLD	O	E-volume LD.
9	BSHIFT	O	Beat shift.
10	RESET	-	Reset.
11	XOUT	-	X'tal (14.318MHz).
12	VSS	-	GND.
13	XIN	-	X'tal (14.318MHz).
14	VCC	-	+5V.
15	GND	-	GND (Input only).
16	NC	I	
17	POWER	I	Power key input.
18	INT	I	μcom stop.
19	NC	I	
20	TX/RX	O	TX/RX.
21	UL	O	PLL unlock detect.
22~25	NC	I	
26	EEPWP	O	EEPROM write protect
27	EEPCK	O	EEPROM clock (N ch open drain).
28	EEPDT	I/O	EEPROM data (N ch open drain).
29	FNC1	I/O	Function P1/TxD for flash.
30	FNC2	I/O	Function P2/RxD for flash.
31	CLKFLS	I	SCLK for flash.
32	BSYFLS	O	Busy for flash.
33	TXD	O	To FPU.
34	RXD	I	From FPU.
35	PTT	I	PTT key.
36	HOOK	I	Hook.
37,38	NC	I	
39	EMPFLS	I/O	EPM for flash.
40~42	NC	I	
43	FNC3	I/O	Function port 3.
44	CEFLS	I/O	CE for flash.
45,46	FNC4, FNC5	I/O	Function port 4, 5
47,48	FNC7, FNC6	I/O	Function port 7, 6.
49	FNC8	I/O	Function port 8.
50	AFM	O	AF mute.
51	SPM	O	Speaker mute.

Pin No.	Name	I/O	Function
52	AMPSW	O	AF AMP switch.
53	DT	O	Common data.
54	CK	O	Common clock.
55,56	NC	I	
57~59	DST1~DST3	I	Destination 1~3
60	VCC	-	+5V.
61	NC	I	
62	VSS	-	GND.
63	NC	I	
64	NARROW	O	
65	WIDE	O	
66~68	NC	I	
69	CL	O	Clock for LCD.
70	CE	O	Chip enable for LCD.
71	DI	O	Transfer data to LCD.
72	IGN	I	Ignition.
73	MICMT1	O	Mic 1 mute.
74	MICEM	O	Mic 2 mute.
75	MICMT2	O	Mic 3 mute.
76	8RC	O	8R control.
77	8TC	O	8T control.
78	CM	I/O	Mic key check.
79~81	NC	I	
82	SBC	O	Battery switch.
83	KMI2	I	Key matrix 2.
84	KMI1	I	Key matrix 1.
85	KMI3	I	Key matrix 3.
86	KMI4	I	Key matrix 4.
87	NC	I	
88	SIGNAL	I	DTMF/QT/DQT input.
89	TEMP2	I	Temperature 2.
90	TEMP1	I	Temperature 1.
91	BATT	I	Battery voltage.
92	RSSI	I	RSSI input.
93	SQIN	I	Squelch input.
94	AVSS	-	GND.
95	NC	I	
96	VREF	-	+5V.
97	AVCC	-	+5V.
98	NC	I	
99	KMO1	O	Key matrix output 1.
100	KMO2	O	Key matrix output 2.



## COMPONENTS DESCRIPTION

## Display Unit (X54-3460-20)

Ref. No.	Parts name	Description
IC1	IC	Shift register for LED & MICBL control
Q4	Transistor	Busy light switch
Q9,10	Transistor	Key backlit switch
D1~4	LED	Key backlit
D5	LED	Monitor key light
D6	LED	Programmable key light
D7~10	LED	Channel key light
D11	LED	Busy
D12	LED	Transmit
D13	Diode	Surge protection

## TX-RX Unit (X57-6920-XX)

Ref. No.	Parts name	Description
IC31	IC	Voltage regulator (8C)
IC32	IC	Voltage regulator (5C)
IC33	IC	Voltage regulator (5M)
IC34	IC	Voltage detector reset
IC35	IC	Voltage detector int
IC66	IC	EEPROM
IC101	IC	CPU
IC161	IC	Digital potentiometer
IC201	IC	MIC amplifier / IDC
IC202	IC	MIC amplifier / Splatter filter
IC203	IC	Buffer amplifier / SUM amplifier / DC amplifier / 1/2 Vcc
IC251	IC	Audio filter
IC252	IC	Audio amplifier
IC301	IC	FM demodulation
IC401	IC	PLL synthesizer
IC501	IC	APC controller
IC502	IC	Power module
Q1	Transistor	TX AF
Q31	Transistor	DC switch (SB) / Active when power is on
Q32	FET	DC switch (SB) / Active when power is on
Q33,34	Transistor	DC switch (8R) / Active while RX
Q35,36	Transistor	DC switch (8T) / Active while TX
Q61	Transistor	Over voltage detection / Active when PS voltage is more than 18V
Q71	Transistor	Ignition / Ignition sens
Q86,87	Transistor	Beat shift / Active while beat shift is on
Q201	Transistor	AF amplifier / MIC mute / Emergency MIC mute
Q202	FET	Emergency MIC mute / Active when MICEM is H
Q251	Transistor	Buffer amplifier / RX audio

Ref. No.	Parts name	Description
Q252,253	FET	AF mute / Active while AFM is H
Q254	Digital transistor	AF mute / Active while SPM is H
Q255	Transistor	AF mute / Active while AMPSW is H
Q301	Transistor	SQL amplifier / Noie amplifier
Q302	Transistor	Buffer amplifier / 16.8MHz 3rd over tone
Q351	Transistor	IF amplifier
Q352	FET	Mixer
Q353	FET	RF amplifier / LNA
Q402,403	Transistor	Charge pump
Q404	Transistor	RF amplifier / PLL F in
Q405	FET	RX VCO
Q406	FET	TX VCO
Q407	FET	T/R SW
Q408	Transistor	T/R SW
Q410	Transistor	Buffer amplifier / Output of VCO
Q411	Transistor	RF amplifier / Output of VCO
Q440	Transistor	Lipple filter
Q500	Transistor	RF switch (TX/RX)
Q501,502	Transistor	RF amplifier
D1	Diode	Surge absorption / CM
D2	Diode	Surge absorption / HOOK
D3	Diode	Surge absorption / PTT
D4~11	Diode	Surge absorption / FNC1~8
D31	Diode	Reverse connection protection
D32	Poly switch	Current protection
D61	Diode	Over voltage detection
D201	Diode	OR gate / MIC mute, AGC
D202	Diode	AGC
D251	Diode	Limiter
D301	Diode	Detection
D302,303	Diode	IF switch (Wide/Narrow)
D351~355	Varicap	RF BPF tuning
D401	Diode	Lipple filter
D402	Diode	Voltage dropped
D403,404	Varicap	RX VCO
D405,406	Varicap	TX VCO
D407	Varicap	Modulation
D408	Diode	Lipple filter
D409	Diode	RF switch (TX/RX)
D502	Diode	Temperature compensation
D503	Diode	Voltage protectionV
D602	Diode	ANT switch
D604,605	Diode	ANT switch
D606,607	Diode	APC voltage detectV
D608,609	Diode	Temperature compensation

## PARTS LIST

\* New Parts.  $\Delta$  indicates safety critical components.

Parts without **Parts No.** are not supplied.

Les articles non mentionnés dans le **Parts No.** ne sont pas fournis.

Teile ohne **Parts No.** werden nicht geliefert.

L : Scandinavia

Y : PX (Far East, Hawaii)

Y : AAFES (Europe)

K : USA

T : England

X : Australia

P : Canada

E : Europe

M : Other Areas

### TK-8102

DISPLAY UNIT (X54-3460-20)

TX-RX UNIT (X57-6920-XX)

Ref. No.	Address	New parts	Parts No.	Description	Desti-nation	Ref. No.	Address	New parts	Parts No.	Description	Desti-nation
<b>TK-8102</b>											
1	1B		A01-2178-02	CABINET		CN1			E40-6005-05	FLAT CABLE CONNECTOR	
2	3B	*	A10-4080-01	CHASSIS		J1			E08-0877-05	MODULAR JACK	
3	3A		A62-0942-03	PANEL ASSY		L1			L92-0138-05	FERRITE CHIP	
5	3A	*	B10-2753-03	FRONT GLASS		CP3,4			RK75GB1J392J	CHIP-COM 3.9K J 1/16W	
7	2C		B62-1389-10	INSTRUCTION MANUAL		R1-6			RK73GB1J102J	CHIP R 1.0K J 1/16W	
8	3B	*	B72-1946-24	MODEL NAME PLATE	M	R7-15			RK73FB2A272J	CHIP R 2.7K J 1/10W	
8	3B	*	B72-1947-14	MODEL NAME PLATE	M2	R16			RK73GB1J101J	CHIP R 100 J 1/16W	
8	3B	*	B72-1948-14	MODEL NAME PLATE	M3	R17			RK73GB1J100J	CHIP R 10 J 1/16W	
10	3B		E04-0167-05	RF COAXIAL PECEPTACLE (M)		R18			RK73GB1J472J	CHIP R 4.7K J 1/16W	
12	1C		E30-3339-05	DC CORD ACCESSORY		R19,20			RK73GB1J222J	CHIP R 2.2K J 1/16W	
13	2B		E30-3448-05	DC CORD (RADIO)		D13			DA221	DIODE	
14	3A		E37-0962-05	SPEAKER CABLE		IC1			BU2090FS	MOS IC	
15	2A		E37-1041-05	FLAT CABLE (TX/RX-DISPLAY)		Q4			KRC102S	DIGITAL TRANSISTOR	
20	2B		F10-2414-03	SHIELDING PLATE (POWER MODULE)		Q9			KRA225S	DIGITAL TRANSISTOR	
21	2B	*	F10-2491-02	SHIELDING COVER (TX/RX)		Q10			KRC102S	DIGITAL TRANSISTOR	
22	2B	*	F10-2498-03	SHIELDING CASE (POWER MODULE)		<b>TX-RX UNIT (X57-6920-XX) -22 : M -23 : M2 -24 : M3</b>					
23	1C		F51-0016-05	FUSE (6*30) ACCESSORY		C10			CK73GB1H102K	CHIP C 1000PF K	
25	2B		G02-0887-03	EARTH SPRING (ANTENNA TERMINAL)		C13-23			CK73GB1H471K	CHIP C 470PF K	
26	2B		G10-0792-14	FIBROUS SHEET (POWER MODULE)		C26-28			CK73GB1H221K	CHIP C 220PF K	
27	3A		G13-1836-04	CUSHION (SPEAKER)		C29			CK73GB1H471K	CHIP C 470PF K	
30	3B	*	G13-2003-04	CUSHION (DC CORD)		C30			CK73GB1H102K	CHIP C 1000PF K	
34	1B		G53-1524-02	PACKING (CABINET)		C32			CK73GB1H102K	CHIP C 1000PF K	
35	3B		G53-1525-03	PACKING (PANEL)		C33			CK73GB1H471K	CHIP C 470PF K	
36	2B		G53-1542-03	PACKING (PHONE JACK)		C34			C92-0721-05	ELECTRO 330UF 25WV	
38	1C		H02-0617-02	INNER PACKING CASE		C35-38			CK73GB1H471K	CHIP C 470PF K	
39	2D		H10-6636-13	POLYSTYRENE FOAMED FIXTURE		C39,40			CK73GB1C104K	CHIP C 0.10UF K	
40	3C		H10-6639-03	POLYSTYRENE FOAMED FIXTURE		C41			C92-0795-05	CHIP-TAN 22UF 10WV	
41	1C		H25-0103-04	PROTECTION BAG (125/250/0.07)		C42			CK73GB1H103K	CHIP C 0.010UF K	
42	2D		H25-2320-04	PROTECTION BAG		C43-45			C92-0795-05	CHIP-TAN 22UF 10WV	
43	3D		H52-1699-12	ITEM CARTON CASE		C48			CK73GB1C473K	CHIP C 0.047UF K	M
46	1D		J29-0662-03	BRACKET ACCESSORY		C48-50			CK73GB1H103K	CHIP C 0.010UF K	M2,M3
48	2A		K29-9065-01	KEY TOP		C49,50			CK73GB1H103K	CHIP C 0.010UF K	M
A	2B		N67-3008-46	PAN HEAD SEMS SCREW W		C51			C92-0560-05	CHIP-TAN 10UF 6.3WV	
B	2B,3B		N87-2606-46	BRAZIER HEAD TAPTITE SCREW		C52,53			CK73GB1H471K	CHIP C 470PF K	
C	1B,2B		N87-2614-46	BRAZIER HEAD TAPTITE SCREW		C54,55			CK73GB1C104K	CHIP C 0.10UF K	
50	1C		N99-0395-05	SCREW SET ACCESSORY		C56			CK73GB1H471K	CHIP C 470PF K	
52	3A		T07-0739-05	SPEAKER		C61			CK73GB1H471K	CHIP C 470PF K	
<b>DISPLAY UNIT (X54-3460-20)</b>						C66			CK73GB1H471K	CHIP C 470PF K	
D1-4			B30-2238-05	LED (Y)		C72			CK73GB1H471K	CHIP C 470PF K	
D5-10			B30-2239-05	LED (SY)		C77			CK73GB1H471K	CHIP C 470PF K	
D11			B30-2237-05	LED (YG)		C78			CK73GB1H102K	CHIP C 1000PF K	
D12			B30-2240-05	LED (SR)		C82			CK73GB1H471K	CHIP C 470PF K	
C4			CK73GB1H103K	CHIP C 0.010UF K		C83			CK73GB1C104K	CHIP C 0.10UF K	
C8-17			CK73GB1H103K	CHIP C 0.010UF K		C87			CC73GCH1H180J	CHIP C 18PF J	
C18			CK73GB1A105K	CHIP C 1.0UF K		C88,89			CC73GCH1H060B	CHIP C 6.0PF B	
C25			CK73GB1H103K	CHIP C 0.010UF K		C90			CC73GCH1H180J	CHIP C 18PF J	
C27			CK73GB1C104K	CHIP C 0.10UF K		C97,98			CK73GB1H471K	CHIP C 470PF K	
						C101			CK73GB1H471K	CHIP C 470PF K	
						C102			CK73GB1C104K	CHIP C 0.10UF K	
						C103			CK73GB1H102K	CHIP C 1000PF K	
						C104			CK73GB1C104K	CHIP C 0.10UF K	

## PARTS LIST

### TX-RX UNIT (X57-6920-XX)

Ref. No.	Address	New parts	Parts No.	Description	Destination	Ref. No.	Address	New parts	Parts No.	Description	Destination
C151			CK73GB1H182K	CHIP C 1800PF K		C302,303			CK73GB1H102K	CHIP C 1000PF K	M3
C152			CK73GB1H392K	CHIP C 3900PF K		C303			CK73GB1H472K	CHIP C 4700PF K	M,M2
C161			CK73GB1H102K	CHIP C 1000PF K		C304,305			CC73GCH1H121J	CHIP C 120PF J	M3
C162			C92-0507-05	CHIP-TAN 4.7UF 6.3WV		C304,305			CC73GCH1H221J	CHIP C 220PF J	M,M3
C163			CK73GB1H471K	CHIP C 470PF K		C306			CK73GB1H102K	CHIP C 1000PF K	
C164			C92-0560-05	CHIP-TAN 10UF 6.3WV		C307			CK73GB1E223K	CHIP C 0.022UF K	
C201			CK73GB1C104K	CHIP C 0.10UF K		C308			CK73GB1H102K	CHIP C 1000PF K	
C202			CK73GB1H471K	CHIP C 470PF K		C309			CK73GB1E223K	CHIP C 0.022UF K	
C203			CK73GB1C273K	CHIP C 0.027UF K		C310			CK73FB1C334K	CHIP C 0.33UF K	
C204			C92-0514-05	CHIP-TAN 2.2UF 10WV		C311,312			CK73GB1C104K	CHIP C 0.10UF K	
C205			CK73GB1C104K	CHIP C 0.10UF K		C313			C92-0662-05	CHIP-TAN 15UF 6.3WV	
C206			CK73GB1H102K	CHIP C 1000PF K		C314			CK73GB1H103K	CHIP C 0.010UF K	
C207			CK73GB1C223K	CHIP C 0.022UF K		C315-318			CK73GB1C104K	CHIP C 0.10UF K	
C208			CK73GB1H103K	CHIP C 0.010UF K		C319			CC73GCH1H101J	CHIP C 100PF J	
C210			CK73GB1C104K	CHIP C 0.10UF K		C321			CC73GCH1H330J	CHIP C 33PF J	
C211			CK73GB1H821K	CHIP C 820PF K		C322			CC73GCH1H560J	CHIP C 56PF J	
C212			CK73GB1H122K	CHIP C 1200PF K		C323			CC73GCH1H271J	CHIP C 270PF J	
C213			CK73GB1H332K	CHIP C 3300PF K		C324			CK73GB1H103K	CHIP C 0.010UF K	
C214			CC73GCH1H151J	CHIP C 150PF J		C326			CK73GB1H103K	CHIP C 0.010UF K	
C215			CK73GB1C104K	CHIP C 0.10UF K		C351			CC73GCH1H330J	CHIP C 33PF J	
C217,218			C92-0560-05	CHIP-TAN 10UF 6.3WV		C353			CK73GB1H103K	CHIP C 0.010UF K	
C220			C92-0507-05	CHIP-TAN 4.7UF 6.3WV		C354			CC73GCH1H060B	CHIP C 6.0PF B	
C221			CK73GB1C104K	CHIP C 0.10UF K		C355			CC73GCH1H180J	CHIP C 18PF J	
C225			C92-0004-05	CHIP-TAN 1.0UF 16WV		C356			CC73GCH1H020B	CHIP C 2.0PF B	
C226			CK73GB1H472K	CHIP C 4700PF K		C357			CK73GB1H103K	CHIP C 0.010UF K	
C227			CK73GB1E103K	CHIP C 0.010UF K		C358			CK73GB1H471K	CHIP C 470PF K	
C228			C92-0560-05	CHIP-TAN 10UF 6.3WV		C359			CC73GCH1H120J	CHIP C 12PF J	
C229			C92-0507-05	CHIP-TAN 4.7UF 6.3WV		C360			CC73GCH1H080B	CHIP C 8.0PF B	
C230			CK73GB1C104K	CHIP C 0.10UF K		C361,362			CK73GB1H471K	CHIP C 470PF K	
C231,232			CK73GB1H471K	CHIP C 470PF K		C363			CK73GB1H103K	CHIP C 0.010UF K	
C233			C92-0507-05	CHIP-TAN 4.7UF 6.3WV		C364			CK73GB1H471K	CHIP C 470PF K	
C250			CK73GB1C104K	CHIP C 0.10UF K		C366			CK73GB1C104K	CHIP C 0.10UF K	
C251			C92-0714-05	CHIP-TAN 4.7UF 6.3WV		C367			CC73GCH1H470J	CHIP C 47PF J	M2
C252			CC73GCH1H390J	CHIP C 39PF J		C367			CK73GB1H471K	CHIP C 470PF K	M,M3
C253,254			CK73GB1A105K	CHIP C 1.0UF K		C368			CC73GCH1H070B	CHIP C 7.0PF B	
C255			CK73GB1H822K	CHIP C 8200PF K		C369			CC73GCH1H1R5B	CHIP C 1.5PF B	M
C256			CK73GB1E183K	CHIP C 0.018UF K		C369			CC73GCH1H060B	CHIP C 6.0PF B	M2
C257			CK73GB1C393K	CHIP C 0.039UF K		C370			CK73GB1H471K	CHIP C 470PF K	
C258-261			CK73GB1H103J	CHIP C 0.010UF J		C371			CC73GCH1H0R5B	CHIP C 0.5PF B	
C262			CK73GB1H471K	CHIP C 470PF K		C372			CC73GCH1H150J	CHIP C 15PF J	
C263,264			CK73GB1C333K	CHIP C 0.033UF K		C373			CC73GCH1H070B	CHIP C 7.0PF B	M2
C265,266			CK73GB1C104K	CHIP C 0.10UF K		C373			CC73GCH1H080B	CHIP C 8.0PF B	M3
C267			CK73GB1A474K	CHIP C 0.47UF K		C373			CC73GCH1H090B	CHIP C 9.0PF B	M
C268			CK73GB1C104K	CHIP C 0.10UF K		C374			CC73GCH1H070B	CHIP C 7.0PF B	
C269			CK73GB1A105K	CHIP C 1.0UF K		C375-380			CK73GB1H471K	CHIP C 470PF K	
C270			C92-0507-05	CHIP-TAN 4.7UF 6.3WV		C381			CC73GCH1H060B	CHIP C 6.0PF B	M2
C271			CK73GB1H332K	CHIP C 3300PF K		C381			CC73GCH1H070B	CHIP C 7.0PF B	M,M3
C272			CK73GB1H102K	CHIP C 1000PF K		C382			CK73GB1H471K	CHIP C 470PF K	
C273			CK73GB1A105K	CHIP C 1.0UF K		C383			CC73GCH1H0R5B	CHIP C 0.5PF B	
C274			CK73FB1C224K	CHIP C 0.22UF K		C384			CC73GCH1H050B	CHIP C 5.0PF B	M2
C275			CK73GB1A105K	CHIP C 1.0UF K		C384			CC73GCH1H070B	CHIP C 7.0PF B	M,M3
C276,277			CK73GB1H471K	CHIP C 470PF K		C385			CK73GB1H471K	CHIP C 470PF K	
C278			CK73GB1C104K	CHIP C 0.10UF K		C386			CC73GCH1HR75B	CHIP C 0.75PF B	M3
C279			C92-0516-05	CHIP-TAN 4.7UF 16WV		C386			CC73GCH1H0R5B	CHIP C 0.5PF B	M,M2
C280			C92-0040-05	CHIP-ELE 47UF 16WV		C388			CC73GCH1H030B	CHIP C 3.0PF B	M2
C281			CK73GB1H471K	CHIP C 470PF K		C388			CC73GCH1H060B	CHIP C 6.0PF B	M,M3
C282			C92-0722-05	ELECTRO 470UF 16WV		C389			CK73GB1H103K	CHIP C 0.010UF K	
C283			CK73GB1H102K	CHIP C 1000PF K		C390			CC73GCH1H050B	CHIP C 5.0PF B	M2
C301			C92-0507-05	CHIP-TAN 4.7UF 6.3WV		C390			CC73GCH1H080B	CHIP C 8.0PF B	M,M3
C302			CK73GB1H102K	CHIP C 1000PF K	M,M2	C391			CK73GB1H471K	CHIP C 470PF K	

## PARTS LIST

TX-RX UNIT (X57-6920-XX)

Ref. No.	Address	New parts	Parts No.	Description	Desti-nation	Ref. No.	Address	New parts	Parts No.	Description	Desti-nation
C401-403			CC73GCH1H101J	CHIP C 100PF J		C504,505			CK73GB1H471K	CHIP C 470PF K	
C404			C92-0662-05	CHIP-TAN 15UF 6.3WV		C507			CK73GB1H471K	CHIP C 470PF K	
C406			CK73GB1H102K	CHIP C 1000PF K		C509			CC73GCH1H050B	CHIP C 5.0PF B	
C408			CC73GCH1H220J	CHIP C 22PF J		C510-515			CK73GB1H471K	CHIP C 470PF K	
C409			CK73GB1C104K	CHIP C 0.10UF K		C516			CC73GCH1H080B	CHIP C 8.0PF B	
C410			C92-0560-05	CHIP-TAN 10UF 6.3WV		C520-522			CK73GB1H471K	CHIP C 470PF K	
C411			CK73GB1C104K	CHIP C 0.10UF K		C523			CC73GCH1H040B	CHIP C 4.0PF B	M,M2
C412			C92-0560-05	CHIP-TAN 10UF 6.3WV		C523			CC73GCH1H070B	CHIP C 7.0PF B	M3
C413			CK73GB1H103K	CHIP C 0.010UF K		C527			CK73GB1H221K	CHIP C 220PF K	
C414			CK73GB1C104K	CHIP C 0.10UF K		C528			C93-0552-05	CHIP C 2.0PF C	M2
C416,417			CK73GB1H471K	CHIP C 470PF K		C531			C92-0543-05	CHIP-TAN 3.3UF 10WV	
C418			CK73GB1H102K	CHIP C 1000PF K		C532			CK73GB1H471K	CHIP C 470PF K	
C421,422			CK73GB1H471K	CHIP C 470PF K		C534			CK73FB1H471K	CHIP C 470PF K	
C423			C92-0555-05	CHIP-TAN 0.047UF 35WV		C537			C92-0719-05	ELECTRO 47UF 25WV	
C424			C92-0543-05	CHIP-TAN 3.3UF 10WV		C538			CK73GB1C104K	CHIP C 0.10UF K	
C425			C92-0001-05	CHIP C 0.1UF 35WV		C539,540			CK73GB1H471K	CHIP C 470PF K	
C426			CC73GCH1H050B	CHIP C 5.0PF B	M2	C559			CK73GB1H103K	CHIP C 0.010UF K	
C426			CC73GCH1H080B	CHIP C 8.0PF B	M3	C560			CK73GB1H471K	CHIP C 470PF K	
C426			CC73GCH1H180J	CHIP C 18PF J	M	C571			CK73GB1H471K	CHIP C 470PF K	
C427			CC73GCH1H040B	CHIP C 4.0PF B	M2	C572,573			CK73GB1H103K	CHIP C 0.010UF K	
C427			CC73GCH1H070B	CHIP C 7.0PF B	M3	C601			CC73GCH1H030B	CHIP C 3.0PF B	M2
C427			CC73GCH1H120G	CHIP C 12PF G	M	C601			CC73GCH1H050B	CHIP C 5.0PF B	M3
C428			CK73GB1H471K	CHIP C 470PF K		C602			C93-0603-05	CHIP C 1000PF K	
C429			CC73GCH1H010B	CHIP C 1.0PF B	M	C603			CC73GCH1H0R5B	CHIP C 0.5PF B	
C429,430			CC73GCH1H020B	CHIP C 2.0PF B	M2,M3	C604			CC73GCH1H020B	CHIP C 2.0PF B	M2,M3
C430			CC73GCH1H060B	CHIP C 6.0PF B	M	C604			CC73GCH1H1R5B	CHIP C 1.5PF B	M
C431			CC73GCH1H030B	CHIP C 3.0PF B	M2,M3	C605			C93-0552-05	CHIP C 2.0PF C	M,M3
C431			CC73GCH1H050B	CHIP C 5.0PF B	M	C605,606			C93-0550-05	CHIP C 1.0PF C	M2
C432			CC73GCH1H0R5B	CHIP C 0.5PF B		C606			C93-0550-05	CHIP C 1.0PF C	M,M3
C433			CK73GB1H471K	CHIP C 470PF K		C607			CC73GCH1H0R5B	CHIP C 0.5PF B	
C434			CC73GCH1H040B	CHIP C 4.0PF B	M2	C608			CC73GCH1H020B	CHIP C 2.0PF B	
C434			CC73GCH1H050B	CHIP C 5.0PF B	M3	C609			C93-0550-05	CHIP C 1.0PF C	
C434			CC73GCH1H080B	CHIP C 8.0PF B	M	C610			C93-0554-05	CHIP C 4.0PF C	M2
C435			CC73GCH1H030B	CHIP C 3.0PF B	M2	C610			C93-0556-05	CHIP C 6.0PF D	M
C435			CC73GCH1H060B	CHIP C 6.0PF B	M,M3	C610			C93-0557-05	CHIP C 7.0PF D	M3
C436			CC73GCH1H0R5B	CHIP C 0.5PF B		C611			C93-0553-05	CHIP C 3.0PF C	M2
C437			CK73GB1H471K	CHIP C 470PF K		C611			C93-0554-05	CHIP C 4.0PF C	M
C438			CC73GCH1H010B	CHIP C 1.0PF B	M	C611			C93-0556-05	CHIP C 6.0PF D	M3
C438			CC73GCH1H1R5B	CHIP C 1.5PF B	M2	C612			C93-0550-05	CHIP C 1.0PF C	M
C438,439			CC73GCH1H020B	CHIP C 2.0PF B	M3	C612			C93-0552-05	CHIP C 2.0PF C	M2,M3
C439			CC73GCH1H020B	CHIP C 2.0PF B	M2	C613,614			CK73GB1H471K	CHIP C 470PF K	
C439			CC73GCH1H030B	CHIP C 3.0PF B	M	TC352			C05-0400-05	CERAMIC TRIMMER CAP (3PF)	M3
C440			CC73GCH1H030B	CHIP C 3.0PF B	M2,M3	TC352,353			C05-0399-05	CERAMIC TRIMMER CAP (6PF)	M,M2
C440			CC73GCH1H040B	CHIP C 4.0PF B	M	TC353			C05-0399-05	CERAMIC TRIMMER CAP (6PF)	M3
C441			CC73GCH1H0R3B	CHIP C 0.3PF B		TC401			C05-0245-05	CERAMIC TRIMMER CAP (10PF)	M3
C442			C92-0560-05	CHIP-TAN 10UF 6.3WV		TC401,402			C05-0245-05	CERAMIC TRIMMER CAP (10PF)	M,M2
C444			CK73GB1H471K	CHIP C 470PF K		TC402			C05-0399-05	CERAMIC TRIMMER CAP (6PF)	M3
C448,449			CK73GB1H471K	CHIP C 470PF K		J1			E11-0425-05	3.5D PHONE JACK (3P)	
C450			C92-0568-05	CHIP-TAN 22UF 10WV		CN1			E40-6268-05	FLAT CABLE CONNECTOR	
C451,452			CK73GB1H471K	CHIP C 470PF K		CN2			E40-5702-05	PIN ASSY	
C454			CC73GCH1H060B	CHIP C 6.0PF B		CN3			E40-6292-05	PIN ASSY	
C455			CC73GCH1H020B	CHIP C 2.0PF B		CN5			E40-3246-05	PIN ASSY	
C456			CC73GCH1H040B	CHIP C 4.0PF B		CN301-304			E23-1081-05	TERMINAL	
C461			CK73GB1H471K	CHIP C 470PF K		CN501-503			E23-1081-05	TERMINAL	
C463,464			CK73GB1H471K	CHIP C 470PF K		CF301			L72-0993-05	CERAMIC FILTER	
C466			CC73GCH1H050B	CHIP C 5.0PF B		CF302			L72-0999-05	CERAMIC FILTER	
C467			CK73GB1H471K	CHIP C 470PF K		L101			L92-0443-05	FERRITE CHIP	
C501			CK73GB1H471K	CHIP C 470PF K		L201			L92-0443-05	FERRITE CHIP	
C502			CC73GCH1H020B	CHIP C 2.0PF B	M,M2	L301			L34-4554-05	COIL	
C502			CC73GCH1H050B	CHIP C 5.0PF B	M3						

## PARTS LIST

### TX-RX UNIT (X57-6920-XX)

Ref. No.	Address	New parts	Parts No.	Description	Desti-nation	Ref. No.	Address	New parts	Parts No.	Description	Desti-nation
L302			L41-3385-08	SMALL FIXED INDUCTOR		R36			RK73GB1J152J	CHIP R 1.5K J 1/16W	
L303,304			L40-3381-86	SMALL FIXED INDUCTOR (0.33UH)		R37			RK73GB1J103J	CHIP R 10K J 1/16W	
L351,352			L40-4785-85	SMALL FIXED INDUCTOR (0.47UH)		R38			RK73GB1J334J	CHIP R 330K J 1/16W	
L354			L34-4603-05	AIR-CORE COIL	M2	R39			RK73GB1J474J	CHIP R 470K J 1/16W	
L354,355			L34-4604-05	AIR-CORE COIL	M	R40			RK73GB1J394J	CHIP R 390K J 1/16W	
L354,355			L34-4605-05	AIR-CORE COIL	M3	R41			RK73GB1J334J	CHIP R 330K J 1/16W	
L355			L34-4604-05	AIR-CORE COIL	M2	R61			RK73GB1J471J	CHIP R 470 J 1/16W	
L356			L40-1875-92	SMALL FIXED INDUCTOR (18NH)	M,M2	R62			RK73GB1J102J	CHIP R 1.0K J 1/16W	
L356			L40-2275-92	SMALL FIXED INDUCTOR (22NH)	M3	R66,67			RK73GB1J473J	CHIP R 47K J 1/16W	
L357			L40-3975-92	SMALL FIXED INDUCTOR (39NH)		R68,69			RK73GB1J102J	CHIP R 1.0K J 1/16W	
L358			L34-4603-05	AIR-CORE COIL	M2	R70			RK73GB1J473J	CHIP R 47K J 1/16W	
L358-361			L34-4604-05	AIR-CORE COIL	M	R71			RK73GB1J472J	CHIP R 4.7K J 1/16W	
L358,359			L34-4605-05	AIR-CORE COIL	M3	R72			RK73GB1J105J	CHIP R 1.0M J 1/16W	
L359-361			L34-4604-05	AIR-CORE COIL	M2	R73			RK73GB1J104J	CHIP R 100K J 1/16W	
L360,361			L34-4604-05	AIR-CORE COIL	M3	R74			RK73GB1J473J	CHIP R 47K J 1/16W	
L403			L41-1005-08	SMALL FIXED INDUCTOR		R75			RK73GB1J102J	CHIP R 1.0K J 1/16W	
L404			L92-0442-05	FERRITE CHIP		R76			RK73GH1J183D	CHIP R 18K D 1/16W	
L405			L92-0443-05	FERRITE CHIP		R77	*		RK73GH1J134D	CHIP R 130K D 1/16W	
L406,407			L40-2785-92	SMALL FIXED INDUCTOR (270NH)	M2,M3	R78			RK73GB1J102J	CHIP R 1.0K J 1/16W	
L406,407			L40-4791-86	SMALL FIXED INDUCTOR (4.7UH)	M	R81			RK73GB1J473J	CHIP R 47K J 1/16W	
L408			L40-2778-67	SMALL FIXED INDUCTOR (27NH)	M	R82			R92-1252-05	CHIP R 0 OHM J 1/16W	
L408			L40-3978-67	SMALL FIXED INDUCTOR (39NH)	M2	R86			R92-1252-05	CHIP R 0 OHM J 1/16W	
L408			L40-5678-67	SMALL FIXED INDUCTOR (56NH)	M3	R87			RK73GB1J102J	CHIP R 1.0K J 1/16W	
L409			L40-1885-92	SMALL FIXED INDUCTOR (180NH)	M2	R91,92			RK73GB1J102J	CHIP R 1.0K J 1/16W	
L409-412			L40-2785-92	SMALL FIXED INDUCTOR (270NH)	M3	R93			RK73GB1J123J	CHIP R 12K J 1/16W	
L409,410			L40-4791-86	SMALL FIXED INDUCTOR (4.7UH)	M	R94			RK73GB1J103J	CHIP R 10K J 1/16W	
L410-412			L40-2785-92	SMALL FIXED INDUCTOR (270NH)	M2	R101,102			RK73GB1J473J	CHIP R 47K J 1/16W	
L411,412			L40-2702-86	SMALL FIXED INDUCTOR (27UH)	M	R103-106			RK73GB1J102J	CHIP R 1.0K J 1/16W	
L413			L40-2778-67	SMALL FIXED INDUCTOR (27NH)	M	R107,108			RK73GB1J473J	CHIP R 47K J 1/16W	
L413			L40-3378-67	SMALL FIXED INDUCTOR (33NH)	M2	R109			RK73GB1J152J	CHIP R 1.5K J 1/16W	
L413			L40-4778-67	SMALL FIXED INDUCTOR (47NH)	M3	R110			RK73GB1J473J	CHIP R 47K J 1/16W	
L414			L40-1885-92	SMALL FIXED INDUCTOR (180NH)	M2,M3	R111			RK73GB1J102J	CHIP R 1.0K J 1/16W	
L414,415			L40-2702-86	SMALL FIXED INDUCTOR (27UH)	M	R112,113			RK73GB1J473J	CHIP R 47K J 1/16W	
L415			L40-2785-92	SMALL FIXED INDUCTOR (270NH)	M2,M3	R114-119			RK73GB1J102J	CHIP R 1.0K J 1/16W	
L416,417			L92-0443-05	FERRITE CHIP		R120			R92-1252-05	CHIP R 0 OHM J 1/16W	
L418			L41-2775-06	SMALL FIXED INDUCTOR		R122,123			R92-1252-05	CHIP R 0 OHM J 1/16W	
L420			L41-2775-06	SMALL FIXED INDUCTOR		R124			RK73GB1J473J	CHIP R 47K J 1/16W	
L501			L41-2775-06	SMALL FIXED INDUCTOR		R125-128			RK73GB1J102J	CHIP R 1.0K J 1/16W	
L502			L41-1875-08	SMALL FIXED INDUCTOR		R129			R92-1252-05	CHIP R 0 OHM J 1/16W	
L504			L41-1275-08	SMALL FIXED INDUCTOR	M,M2	R130,131			RK73GB1J102J	CHIP R 1.0K J 1/16W	
L504			L41-2275-08	SMALL FIXED INDUCTOR	M3	R151			RK73GB1J103J	CHIP R 10K J 1/16W	
L505			L92-0179-05	FERRITE CHIP		R152			RK73GB1J472J	CHIP R 4.7K J 1/16W	
L509			L34-4667-05	AIR-CORE COIL		R161			RK73GB1J122J	CHIP R 1.2K J 1/16W	
L601			L34-4669-05	AIR-CORE COIL		R162			RK73GB1J152J	CHIP R 1.5K J 1/16W	
L602,603			L34-1039-05	AIR-CORE COIL		R163			RK73GB1J473J	CHIP R 47K J 1/16W	
L604			L34-4667-05	AIR-CORE COIL		R164-166			RK73GB1J102J	CHIP R 1.0K J 1/16W	
X86			L77-1934-05	CRYSTAL RESONATOR (14.31818MHZ)		R201			RK73GB1J681J	CHIP R 680 J 1/16W	
X401			L77-1868-15	TCXO (16.8MHZ)		R202			R92-0670-05	CHIP R 0 OHM	
XF351			L71-0591-05	MCF (49.95MHZ)		R203			RK73GB1J104J	CHIP R 100K J 1/16W	
R1			RK73GB1J101J	CHIP R 100 J 1/16W		R204			RK73GB1J183J	CHIP R 18K J 1/16W	
R2			R92-1252-05	CHIP R 0 OHM J 1/16W		R205			RK73GB1J821J	CHIP R 820 J 1/16W	
R3			RK73GB1J102J	CHIP R 1.0K J 1/16W		R206			RK73GB1J101J	CHIP R 100 J 1/16W	
R4			RK73GB1J332J	CHIP R 3.3K J 1/16W		R207			RK73GB1J754J	CHIP R 750K J 1/16W	
R5			RK73GB1J223J	CHIP R 22K J 1/16W		R208			RK73GB1J152J	CHIP R 1.5K J 1/16W	
R31			RK73GB1J472J	CHIP R 4.7K J 1/16W		R209			RK73GB1J244J	CHIP R 240K J 1/16W	
R32			R92-1201-05	CHIP R 220 J 1/2W		R211,212			RK73GB1J823J	CHIP R 82K J 1/16W	
R33			RK73GB1J473J	CHIP R 47K J 1/16W		R213			RK73GB1J334J	CHIP R 330K J 1/16W	
R34			RK73GB1J472J	CHIP R 4.7K J 1/16W		R214,215			RK73GB1J683J	CHIP R 68K J 1/16W	
R35			RK73GB1J473J	CHIP R 47K J 1/16W		R216			RK73GB1J274J	CHIP R 270K J 1/16W	
						R217			RK73GB1J224J	CHIP R 220K J 1/16W	

## PARTS LIST

TX-RX UNIT (X57-6920-XX)

Ref. No.	Address	New parts	Parts No.	Description	Desti-nation	Ref. No.	Address	New parts	Parts No.	Description	Desti-nation
R218			RK73GB1J823J	CHIP R 82K J 1/16W		R314			RK73GB1J222J	CHIP R 2.2K J 1/16W	
R219			RK73GB1J563J	CHIP R 56K J 1/16W		R315			RK73GB1J183J	CHIP R 18K J 1/16W	
R220,221			RK73GH1J153D	CHIP R 15K D 1/16W		R316			RK73GB1J223J	CHIP R 22K J 1/16W	
R222			RK73GB1J102J	CHIP R 1.0K J 1/16W		R317-320			RK73GB1J103J	CHIP R 10K J 1/16W	
R223			RK73GB1J472J	CHIP R 4.7K J 1/16W		R321			RK73GB1J223J	CHIP R 22K J 1/16W	
R224			RK73GB1J102J	CHIP R 1.0K J 1/16W		R322			RK73GB1J101J	CHIP R 100 J 1/16W	
R225			RK73GB1J154J	CHIP R 150K J 1/16W		R323			RK73GB1J154J	CHIP R 150K J 1/16W	
R226			RK73GB1J104J	CHIP R 100K J 1/16W		R324			R92-1252-05	CHIP R 0 OHM J 1/16W	
R227			RK73GB1J223J	CHIP R 22K J 1/16W		R325			RK73GB1J333J	CHIP R 33K J 1/16W	
R228			RK73GB1J103J	CHIP R 10K J 1/16W		R351			RK73GB1J471J	CHIP R 470 J 1/16W	
R229			RK73GB1J684J	CHIP R 680K J 1/16W		R352			RK73GB1J101J	CHIP R 100 J 1/16W	
R230			RK73GB1J124J	CHIP R 120K J 1/16W		R353			RK73GB1J104J	CHIP R 100K J 1/16W	
R231			RK73GB1J683J	CHIP R 68K J 1/16W		R354			RK73GB1J561J	CHIP R 560 J 1/16W	
R232			RK73GB1J912J	CHIP R 9.1K J 1/16W		R355			RK73GB1J681J	CHIP R 680 J 1/16W	
R233			RK73GB1J682J	CHIP R 6.8K J 1/16W		R358			RK73GB1J470J	CHIP R 47 J 1/16W	
R249-251			RK73GB1J473J	CHIP R 47K J 1/16W		R359			RK73GB1J334J	CHIP R 330K J 1/16W	
R252			RK73GB1J474J	CHIP R 470K J 1/16W		R360			RK73GB1J474J	CHIP R 470K J 1/16W	
R253			R92-1252-05	CHIP R 0 OHM J 1/16W		R361			RK73GB1J220J	CHIP R 22 J 1/16W	
R254			RK73GB1J681J	CHIP R 680 J 1/16W		R362			RK73GB1J474J	CHIP R 470K J 1/16W	
R255,256			RK73GB1J562J	CHIP R 5.6K J 1/16W		R363			RK73GB1J154J	CHIP R 150K J 1/16W	
R257			RK73GB1J105J	CHIP R 1.0M J 1/16W		R364			R92-1252-05	CHIP R 0 OHM J 1/16W	
R258			RK73GB1J272J	CHIP R 2.7K J 1/16W		R365,366			RK73GB1J104J	CHIP R 100K J 1/16W	
R259			RK73GB1J123J	CHIP R 12K J 1/16W		R367			RK73GB1J101J	CHIP R 100 J 1/16W	
R260			RK73GB1J224J	CHIP R 220K J 1/16W		R369			RK73GB1J151J	CHIP R 150 J 1/16W	
R261			RK73GB1J124J	CHIP R 120K J 1/16W		R370			RK73GB1J474J	CHIP R 470K J 1/16W	
R262			RK73GB1J183J	CHIP R 18K J 1/16W		R371			RK73GB1J394J	CHIP R 390K J 1/16W	
R263			RK73GH1J913D	CHIP R 91K D 1/16W		R372			RK73GB1J684J	CHIP R 680K J 1/16W	
R264			RK73GH1J124D	CHIP R 120K D 1/16W		R373			RK73GB1J184J	CHIP R 180K J 1/16W	
R265			RK73GH1J562D	CHIP R 5.6K D 1/16W		R374			RK73GB1J104J	CHIP R 100K J 1/16W	
R266			RK73GB1J562J	CHIP R 5.6K J 1/16W		R375			R92-1252-05	CHIP R 0 OHM J 1/16W	
R267			R92-0670-05	CHIP R 0 OHM		R376			RK73GB1J104J	CHIP R 100K J 1/16W	
R268			RK73GB1J102J	CHIP R 1.0K J 1/16W		R377			R92-1252-05	CHIP R 0 OHM J 1/16W	
R269			RK73GB1J823J	CHIP R 82K J 1/16W		R378			RK73GB1J104J	CHIP R 100K J 1/16W	
R270			RK73GB1J272J	CHIP R 2.7K J 1/16W		R380			RK73GB1J104J	CHIP R 100K J 1/16W	
R271			RK73GB1J561J	CHIP R 560 J 1/16W		R381			RK73GB1J100J	CHIP R 10 J 1/16W	M3
R272			RK73GB1J152J	CHIP R 1.5K J 1/16W		R381			R92-1252-05	CHIP R 0 OHM J 1/16W	M,M2
R273			RK73GB1J472J	CHIP R 4.7K J 1/16W		R401-403			RK73GB1J102J	CHIP R 1.0K J 1/16W	
R274,275			RK73GB1J153J	CHIP R 15K J 1/16W		R404			RK73GB1J103J	CHIP R 10K J 1/16W	
R276			RK73GB1J473J	CHIP R 47K J 1/16W		R405			R92-1252-05	CHIP R 0 OHM J 1/16W	
R277			RK73GB1J683J	CHIP R 68K J 1/16W		R407			RK73GB1J152J	CHIP R 1.5K J 1/16W	
R278			RK73GB1J123J	CHIP R 12K J 1/16W		R408			RK73GB1J100J	CHIP R 10 J 1/16W	
R279			RK73GB1J472J	CHIP R 4.7K J 1/16W		R409			RK73GB1J104J	CHIP R 100K J 1/16W	
R280			RK73GB1J391J	CHIP R 390 J 1/16W		R410,411			RK73GB1J103J	CHIP R 10K J 1/16W	
R281			R92-0670-05	CHIP R 0 OHM		R412			RK73GB1J123J	CHIP R 12K J 1/16W	
R301,302			RK73GB1J472J	CHIP R 4.7K J 1/16W		R413			RK73GB1J103J	CHIP R 10K J 1/16W	
R303			RK73GB1J223J	CHIP R 22K J 1/16W		R414,415			R92-1252-05	CHIP R 0 OHM J 1/16W	
R304			RK73GB1J123J	CHIP R 12K J 1/16W	M3	R416			RK73GB1J471J	CHIP R 470 J 1/16W	
R304			RK73GB1J472J	CHIP R 4.7K J 1/16W	M,M2	R417			RK73GB1J224J	CHIP R 220K J 1/16W	
R305			RK73GB1J182J	CHIP R 1.8K J 1/16W	M,M2	R418,419			RK73GB1J102J	CHIP R 1.0K J 1/16W	
R305			RK73GB1J183J	CHIP R 18K J 1/16W	M3	R420			RK73GB1J222J	CHIP R 2.2K J 1/16W	
R306			RK73GB1J224J	CHIP R 220K J 1/16W	M3	R421			RK73GB1J152J	CHIP R 1.5K J 1/16W	
R306			RK73GB1J274J	CHIP R 270K J 1/16W	M,M2	R422			RK73GB1J103J	CHIP R 10K J 1/16W	
R308			RK73GB1J334J	CHIP R 330K J 1/16W		R423			RK73GB1J221J	CHIP R 220 J 1/16W	M
R309			RK73GB1J332J	CHIP R 3.3K J 1/16W		R423			RK73GB1J271J	CHIP R 270 J 1/16W	M2
R310			RK73GB1J102J	CHIP R 1.0K J 1/16W		R423			RK73GB1J331J	CHIP R 330 J 1/16W	M3
R311			RK73GB1J273J	CHIP R 27K J 1/16W	M2	R424			RK73GB1J151J	CHIP R 150 J 1/16W	M
R311			RK73GB1J333J	CHIP R 33K J 1/16W	M,M3	R424			RK73GB1J221J	CHIP R 220 J 1/16W	M2
R312			RK73GB1J154J	CHIP R 150K J 1/16W	M2	R424			RK73GB1J271J	CHIP R 270 J 1/16W	M3
R312			RK73GB1J473J	CHIP R 47K J 1/16W	M,M3	R425,426			RK73GB1J473J	CHIP R 47K J 1/16W	
R313			RK73GB1J104J	CHIP R 100K J 1/16W		R427			RK73GB1J104J	CHIP R 100K J 1/16W	



## PARTS LIST

## TX-RX UNIT (X57-6920-XX)

Ref. No.	Address	New parts	Parts No.	Description	Destination	Ref. No.	Address	New parts	Parts No.	Description	Destination
R428			RK73GB1J473J	CHIP R 47K J 1/16W		D251			MA742	DIODE	
R429,430			RK73GB1J101J	CHIP R 100 J 1/16W		D301			MA742	DIODE	
R431			RK73GB1J104J	CHIP R 100K J 1/16W		D302,303			DAN222	DIODE	
R432			RK73GB1J102J	CHIP R 1.0K J 1/16W		D351-355			HVC350B	VARIABLE CAPACITANCE DIODE	M
R433			RK73GB1J472J	CHIP R 4.7K J 1/16W		D351-355			HVC355B	VARIABLE CAPACITANCE DIODE	M2
R434			R92-1252-05	CHIP R 0 OHM J 1/16W		D351,352			HVC350B	VARIABLE CAPACITANCE DIODE	M3
R435			RK73GB1J101J	CHIP R 100 J 1/16W		D353			HVC355B	VARIABLE CAPACITANCE DIODE	M3
R436			RK73GB1J124J	CHIP R 120K J 1/16W		D354,355			HVC350B	VARIABLE CAPACITANCE DIODE	M3
R439			RK73GB1J124J	CHIP R 120K J 1/16W		D401			MA2S111	DIODE	
R440			RK73GB1J101J	CHIP R 100 J 1/16W		D402			HZU5ALL	DIODE	
R441			RK73GB1J102J	CHIP R 1.0K J 1/16W		D403-406			MA2S304	VARIABLE CAPACITANCE DIODE	
R442			RK73GB1J101J	CHIP R 100 J 1/16W		D407			MA360	VARIABLE CAPACITANCE DIODE	
R443			RK73GB1J222J	CHIP R 2.2K J 1/16W		D408			MA2S111	DIODE	
R444			RK73GB1J102J	CHIP R 1.0K J 1/16W		D409			DAN235E	DIODE	
R445,446			R92-1252-05	CHIP R 0 OHM J 1/16W		D502			DA221	DIODE	
R501			RK73GB1J102J	CHIP R 1.0K J 1/16W		D503			02DZ5.1(Y)	ZENER DIODE	
R502			RK73FB2A100J	CHIP R 10 J 1/10W	M,M3	D602			MA4PH633	DIODE	
R502			RK73FB2A330J	CHIP R 33 J 1/10W	M2	D604,605			XB15A709	DIODE	
R506			RK73GB1J124J	CHIP R 120K J 1/16W	M3	D606,607			MA742	DIODE	
R506			RK73GB1J563J	CHIP R 56K J 1/16W	M,M2	D608,609			1SS355	DIODE	
R507			RK73GB1J181J	CHIP R 180 J 1/16W		IC31			KIA7808AF	ANALOG IC	
R509			RK73GB1J101J	CHIP R 100 J 1/16W		IC32,33			NJM78L05UA	BI-POLAR IC	
R511			RK73GB1J471J	CHIP R 470 J 1/16W		IC34,35			PST9140NR	MOS IC	
R512			R92-1252-05	CHIP R 0 OHM J 1/16W		IC66		*	AT24C64A10SI18	ROM IC	
R513			RK73GB1J221J	CHIP R 220 J 1/16W		IC101		*	30622MAA-B87GP	MPU	
R514			RK73GB1J681J	CHIP R 680 J 1/16W		IC161			M62363FP	MOS IC	
R515			RK73GB1J100J	CHIP R 10 J 1/16W		IC201			NJM2100V	MOS IC	
R516			RK73GB1J332J	CHIP R 3.3K J 1/16W		IC202			NJM2904V	MOS IC	
R517			RK73GB1J100J	CHIP R 10 J 1/16W		IC203			NJM2902V	MOS IC	
R519			RK73FB2A331J	CHIP R 330 J 1/10W		IC251			NJM2902V	MOS IC	
R520			RK73GB1J152J	CHIP R 1.5K J 1/16W		IC252	2B		LA4600	BI-POLAR IC	
R521			RK73GB1J101J	CHIP R 100 J 1/16W		IC301			TK14489V	BI-POLAR IC	
R522			R92-0685-05	CHIP R 22 J 1/2W		IC401			MB15A02	MOS IC	
R523			RK73FB2A332J	CHIP R 3.3K J 1/10W		IC501			TA75W01FU	MOS IC	
R524			RK73FB2A181J	CHIP R 180 J 1/10W		IC502	2B		RA30H4047M-31	MOS IC	M3
R525			RK73FB2A330J	CHIP R 33 J 1/10W		IC502	2B		RA30H4452M-31	MOS IC	M,M2
R526			RK73FB2A181J	CHIP R 180 J 1/10W		Q1			2SK1824	FET	
R527			RK73GB1J334J	CHIP R 330K J 1/16W		Q31	2B		KTA1046(Y)	TRANSISTOR	
R528,529			RK73GB1J103J	CHIP R 10K J 1/16W		Q32			2SK1824	FET	
R530			RK73GB1J562J	CHIP R 5.6K J 1/16W		Q33			2SA1745(6,7)	TRANSISTOR	
R531			RK73GB1J473J	CHIP R 47K J 1/16W		Q34			KRC102S	DIGITAL TRANSISTOR	
R532,533			R92-1252-05	CHIP R 0 OHM J 1/16W		Q35			KTA1664(Y)	TRANSISTOR	
R534			RK73GB1J822J	CHIP R 8.2K J 1/16W		Q36			KRC102S	DIGITAL TRANSISTOR	
R535			RK73GB1J102J	CHIP R 1.0K J 1/16W		Q61			KRC404RTK	DIGITAL TRANSISTOR	
R536			RK73EB2B470J	CHIP R 47 J 1/8W		Q71			KRC414RTK	DIGITAL TRANSISTOR	
R537			RK73GB1J152J	CHIP R 1.5K J 1/16W		Q86,87			2SK1824	FET	
R538			R92-0679-05	CHIP R 0 OHM		Q201			2SC4919	TRANSISTOR	
R539			R92-1213-05	CHIP R 100 J 1/2W		Q202			2SJ243	FET	
R601,602			RK73GB1J223J	CHIP R 22K J 1/16W		Q251			2SC4617(S)	TRANSISTOR	
R603			RK73GB1J473J	CHIP R 47K J 1/16W		Q252,253			2SK1824	FET	
R605			RK73GB1J473J	CHIP R 47K J 1/16W		Q254			DTC363EU	DIGITAL TRANSISTOR	
R606			RK73GB1J102J	CHIP R 1.0K J 1/16W		Q255			KRC102S	DIGITAL TRANSISTOR	
R800			R92-1061-05	JUMPER REST 0 OHM		Q301			2SC2412K	TRANSISTOR	
D1-11			DA221	DIODE		Q302			2SC4649(N,P)	TRANSISTOR	
D31			ZSH5MA27	SURGE ABSORBER		Q351			2SC5108(Y)	TRANSISTOR	
D32			1812L110PR	VARISTOR		Q352,353			3SK255	FET	
D61			02DZ18(X,Y)	ZENER DIODE		Q402			2SA1832(GR)	TRANSISTOR	
D201			DAN222	DIODE		Q403			2SC4738(GR)	TRANSISTOR	
D202			1SS372	DIODE		Q404			2SC4649(N,P)	TRANSISTOR	
						Q405,406			2SK508NV(K52)	FET	



## PARTS LIST

TX-RX UNIT (X57-6920-XX)

Ref. No.	Address	New parts	Parts No.	Description	Destination	Ref. No.	Address	New parts	Parts No.	Description	Destination
Q407			2SJ243	FET							
Q408			KRX102U	TRANSISTOR							
Q410,411			2SC5108(Y)	TRANSISTOR							
Q440			2SC4617(S)	TRANSISTOR							
Q500			2SC5108(Y)	TRANSISTOR							
Q501,502			2SC3357	TRANSISTOR							
TH97,98			B57331V2104J	THERMISTOR							
TH301			B57331V2104J	THERMISTOR							
TH351			NCP18XW332J03	THERMISTOR							
TH401			NCP18XH103K03	THERMISTOR	M						

# TK-8102

## EXPLODED VIEW

- A M3 x 8 : N67-3008-46  
 B M2.6 x 6 (Br-Tap) : N87-2606-46  
 C M2.6 x 14 (Br-Tap) : N87-2614-46

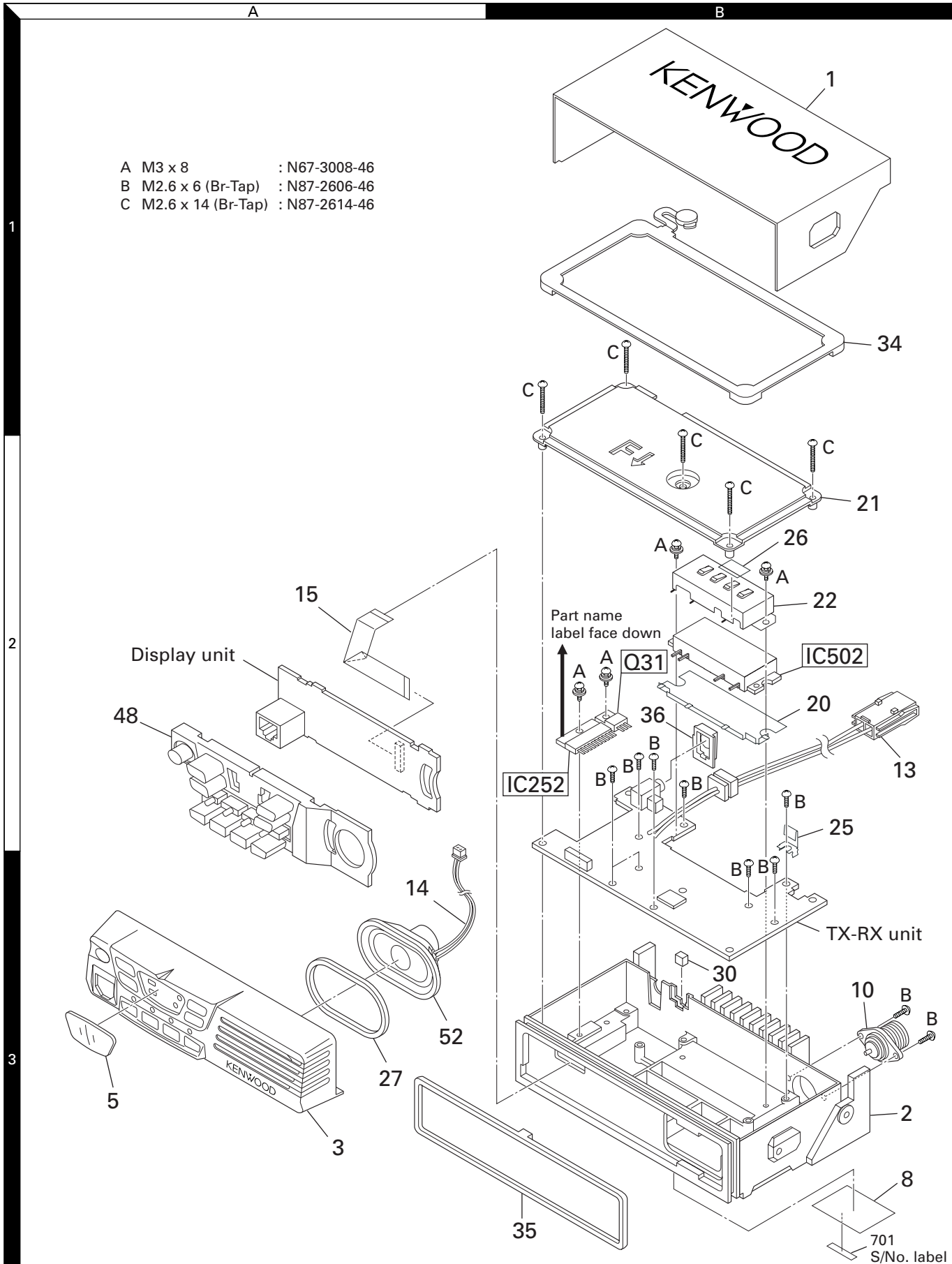

## PACKING

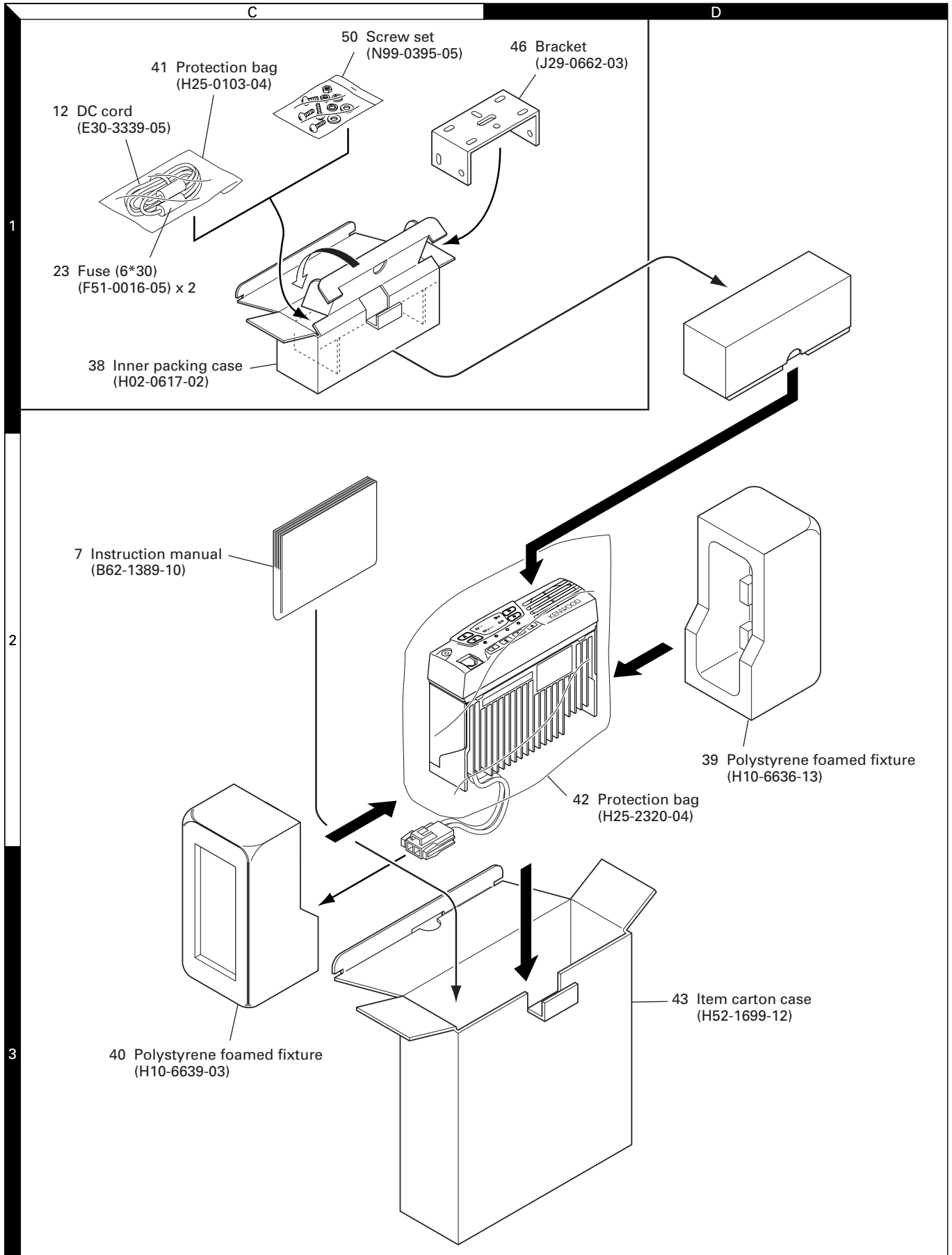

Parts with the exploded numbers larger than 700 are not supplied.

## ADJUSTMENT

### Test Equipment Required for Alignment

Test Equipment	Major Specifications	
1. Standard Signal Generator (SSG)	Frequency Range Modulation Output	400 to 520MHz Frequency modulation and external modulation -127dBm/0.1μV to greater than -7dBm/100mV
2. Power Meter	Input Impedance Operation Frequency Measurement Capability	50Ω 400 to 520MHz or more Vicinity of 100W
3. Deviation Meter	Frequency Range	400 to 520MHz
4. Digital Volt Meter (DVM)	Measuring Range Accuracy	1 to 20V DC High input impedance for minimum circuit loading
5. Oscilloscope		DC through 30MHz
6. High Sensitivity Frequency Counter	Frequency Range Frequency Stability	10Hz to 1000MHz 0.2ppm or less
7. Ammeter		20A
8. AF Volt Meter (AF VTVM)	Frequency Range Voltage Range	50Hz to 10kHz 1mV to 3V
9. Audio Generator (AG)	Frequency Range Output	20Hz to 20kHz or more 0 to 1V
10. Distortion Meter	Capability Input Level	3% or less at 1kHz 50mV to 10Vrms
11. 4Ω Dummy Load		Approx. 4Ω, 10W or more
12. Regulated Power Supply		13.6V, approx. 20A (adjustable from 9 to 17V) Useful if ammeter reequipped
13. Spectrum Analyzer	Center frequency	50KHz to 600MHz
14. Tracking Generator	Output Voltage	100mV or more

### Test cable for microphone input (E30-3360-08)

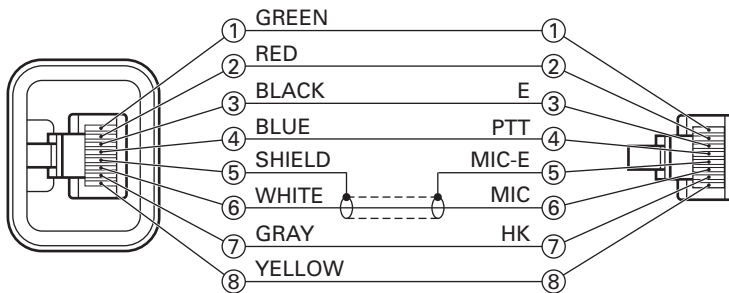

### MIC connector (Front view)

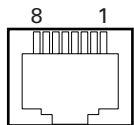

- 1 : BLC
- 2 : PSB
- 3 : E
- 4 : PTT
- 5 : ME
- 6 : MIC
- 7 : HOOK
- 8 : CM

### Tuning cable (E30-3383-05)

Adapter cable (E30-3383-05) is required for injecting an audio if PC tuning is used. See "PC Mode" section for the connection.

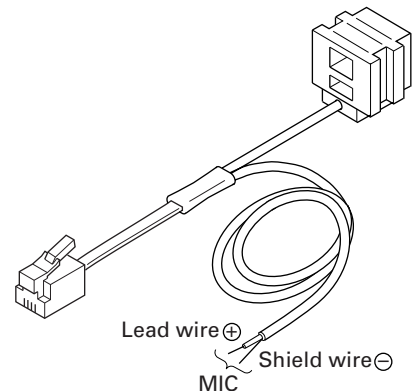

## ADJUSTMENT

### Adjustment Location

#### ■ Switch

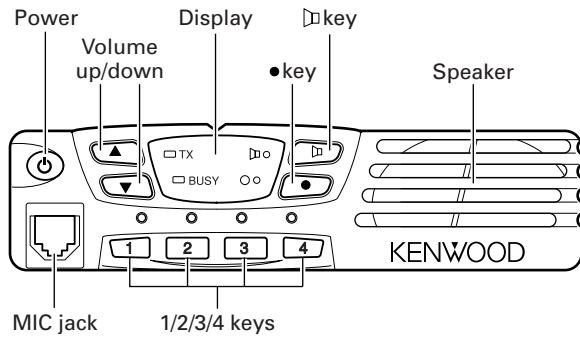

#### ■ Adjustment Points

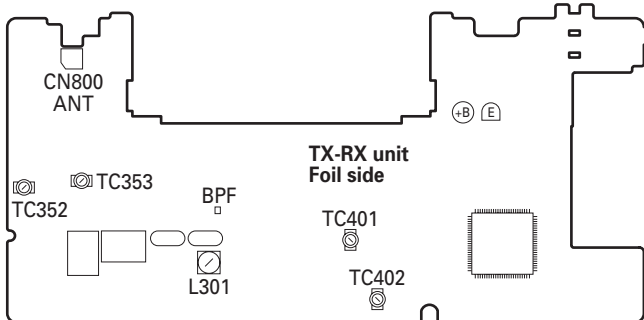
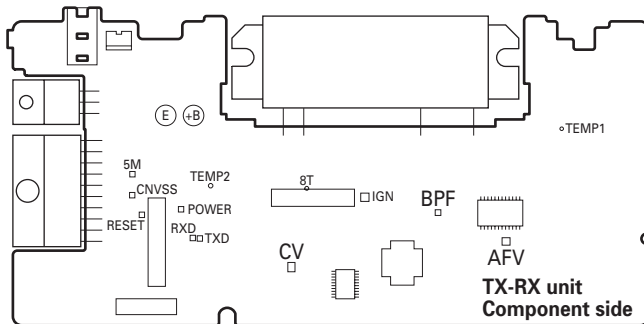

#### ■ Notes

##### • EEPROM

The tuning data (Deviation, Squelch, etc.) for the EEPROM, is stored in memory. When parts are changed, re-adjust the transceiver.

##### • AF PA IC (IC252)

How to mounting the IC252.

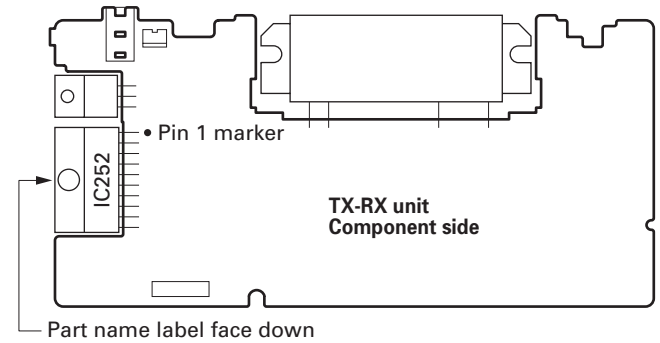

##### • Speaker Cable

The speaker cable should be formed before mounting the shield cover as below.

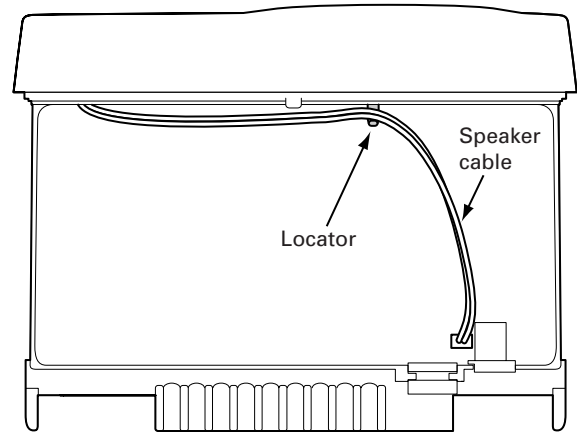

##### • Fuse

To mount the fuse, the cable terminal direction must be as follow.

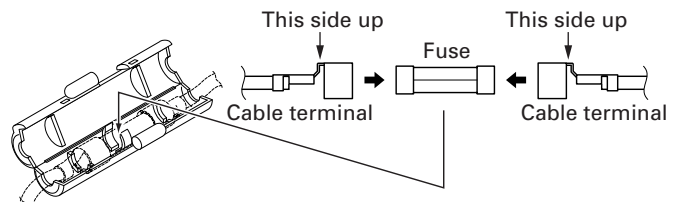

## ADJUSTMENT

### Test Frequency (MHz)

Channel	M		M2		M3	
	TX	RX	TX	RX	TX	RX
1 : Center	470.100	470.050	502.600	502.550	415.100	415.050
2 : Low	450.100	450.050	485.100	485.050	400.100	400.050
3 : High	489.900	489.950	519.900	519.950	429.900	429.950
4	470.000	470.000	498.500	498.500	415.000	415.000
5	470.200	470.200	498.700	498.700	415.200	415.200
6	470.400	470.400	498.900	498.900	415.400	415.400

### PCB Section

Item	Condition	Measurement		Adjustment		Specifications/ Remarks
		Test equipment	Terminal	Parts	Method	
1. Setting	1) Power supply voltage DC Power supply terminal : 13.6V					
2. VCO lock voltage	1) CH : TX high	Digital voltmeter	CV	TC402	5.5V	±0.1V
	2) CH : RX high			TC401	5.5V	±0.1V
	3) CH : TX low				Check	0.7V or more
	4) CH : RX low					
3. IF coil	1) CH : RX center (Wide) 2) SSG output : -53dBm (501μV) Mod : 1kHz Dev : 3kHz	SSG Digital voltmeter	AFV	L301	3.25~3.35V (DC)	
4. RF bandpass filter	1) CH : RX center (Wide) CH : RX low (Wide) CH : RX high (Wide) 2) Track generator output : -30dBm Connect the spectrum analyzer to BPF terminal	Track generator Spectrum analyzer	ANT BPF	TC352 TC353	Adjust the BPF waveform to Fig. 1	

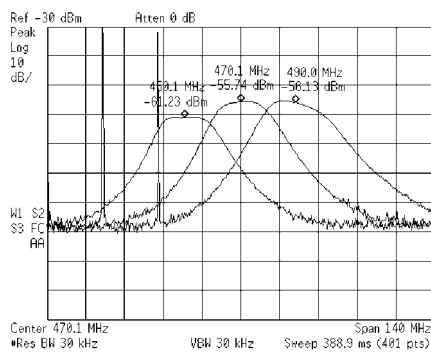

**M**

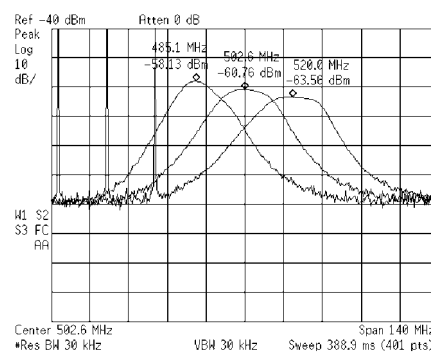

**M2**

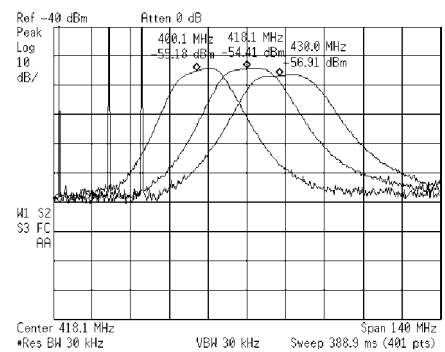

**M3**

**Fig. 1**



## ADJUSTMENT

## Receiver Section

Item	Condition	Measurement		Adjustment		Specifications/ Remarks
		Test equipment	Terminal	Parts	Method	
1. Sensitivity	1) CH : RX low (Wide/Narrow) CH : RX center (Wide/Narrow) CH : RX high (Wide/Narrow) 2) SSG output : -118dBm (0.28 $\mu$ V) (Wide) : -116dBm (0.35 $\mu$ V) (Narrow) Mod : 1kHz Dev : $\pm$ 3.0kHz (Wide) Dev : $\pm$ 1.5kHz (Narrow)	SSG Oscilloscope AF V.M Distortion meter	ANT EXT. SP		Check	SINAD : 12dB or higher
2. Squelch 9	1) CH : RX low (Wide) CH : RX center (Wide/Narrow) CH : RX high (Wide) 2) SSG output : -115dBm (0.4 $\mu$ V) (Wide) : -114dBm (0.45 $\mu$ V) (Narrow) Mod : 1kHz Dev : $\pm$ 3.0kHz (Wide) Dev : $\pm$ 1.5kHz (Narrow)			PC key	Adjust to open the squelch	
3. Squelch 1	1) CH : RX low (Wide) CH : RX center (Wide/Narrow) CH : RX high (Wide) 2) SSG output : -120dBm (0.22 $\mu$ V) (Wide) : -119dBm (0.25 $\mu$ V) (Narrow) Mod : 1kHz Dev : $\pm$ 3.0kHz (Wide) Dev : $\pm$ 1.5kHz (Narrow)					

## Transmitter Section

Item	Condition	Measurement		Adjustment		Specifications/ Remarks
		Test equipment	Terminal	Parts	Method	
1. Frequency	1) CH : TX center 2) Transmit	Frequency counter	ANT	PC key	Adjust to center frequency	Within $\pm$ 100Hz
2. Maximum power check	1) CH : TX high 2) Transmit	Power meter			28W Hex data 255	$\pm$ 1W
3. High power	1) CH : TX low CH : TX low' CH : TX center CH : TX high' CH : TX high 2) Transmit				25W	$\pm$ 1.0W
4. Low power	1) CH : TX low CH : TX low' CH : TX center CH : TX high' CH : TX high 2) Transmit				5W	$\pm$ 1.0W

## ADJUSTMENT

Item	Condition	Measurement		Adjustment		Specifications/ Remarks
		Test equipment	Terminal	Parts	Method	
5. DQT balance	1) CH : TX low (Wide) CH : TX center (Wide/Narrow) CH : TX high (Wide) 2) Transmit	Modulation analyzer or Linear detector (LPF : 3kHz) Oscilloscope	ANT	PC key	Adjust the waveform as below 	
6. MAX balance	1) CH : TX low (Wide) CH : TX center (Wide/Narrow) CH : TX high (Wide) 2) AG : 1kHz/50mV 3) Transmit	Modulation analyzer or Linear detector (LPF : 15kHz) Oscilloscope AG AF V.M	ANT MIC		±4.0kHz (Wide) ±2.0kHz (Narrow) According to the large +, -	±50Hz
7. MIC sensitivity	1) CH : TX center (Wide/Narrow) 2) AG : 1kHz/5mV 3) Transmit				Check	±3kHz±0.2kHz (Wide) ±1.5kHz±0.1kHz (Narrow)
8. DQT deviation	1) CH : TX low (Wide) CH : TX center (Wide/Narrow) CH : TX high (Wide) 2) Transmit	Modulation analyzer or Linear detector (LPF : 3kHz) Oscilloscope			±0.75kHz (Wide) ±0.35kHz (Narrow)	±0.05kHz
9. QT deviation	1) CH : TX low (Wide) CH : TX center (Wide/Narrow) CH : TX high (Wide) 2) Transmit				±0.75kHz (Wide) ±0.35kHz (Narrow)	±0.05kHz
10. DTMF deviation	1) CH : TX center (Wide/Narrow) 2) Transmit				±3.0kHz (Wide) ±1.5kHz (Narrow)	±0.2kHz

# TERMINAL FUNCTION

## CN1

No.	Name	I/O	Function
1	DI		Data
2	CL		Clock
3	CE		Chip enable
4	5C		5V
5	SB		Switched B
6	KMO2	O	Key matrix output 2
7	KMI4	I	Key matrix input 4
8	KMO1	O	Key matrix output 1
9	KMI3	I	Key matrix input 3
10	KMI1	I	Key matrix input 1
11	CM		MIC data detection
12	KMI2	I	Key matrix input 2
13	HOOK		Hook detection/RXD
14	ME		MIC ground
15	POWER		Power switch
16	MIC	I	MIC signal input
17	PTT		PTT/TXD
18	GND		Ground

## CN2

No.	Name	I/O	Function
1	SB	O	Battery voltage DC supply
2	NC	-	-
3	GND	O	Ground
4	DETO2	O	FM detector output
5	FNC1	I/O	Programable I/O (programmed by FPU)
6	FNC2	I/O	Programable I/O (programmed by FPU)
7	FNC3	I/O	Programable I/O (programmed by FPU)
8	FNC4	I/O	Programable I/O (programmed by FPU)
9	FNC5	I/O	Programable I/O (programmed by FPU)
10	FNC6	I/O	Programable I/O (programmed by FPU)
11	FNC7	I/O	Programable I/O (programmed by FPU)
12	FNC8	I/O	Programable I/O (programmed by FPU)

## Function Port Assignment

KDS100, KGP-2A/2B		
	Name	I/O
FNC1	-	-
FNC2	-	-
FNC3	Data Channel	I
FNC4	PTT	I
FNC5	Carrier Operated Relay	O
FNC6	Audio Mute	I
FNC7	Mic Mute	I
FNC8	TX Relay	O
SmarTrunk II		
	Name	I/O
FNC1	TXD	O
FNC2	RXD	I
FNC3	Reset	O
FNC4	-	-
FNC5	-	-
FNC6	-	-
FNC7	-	-
FNC8	-	-
Scrambler		
	Name	I/O
FNC1	-	-
FNC2	-	-
FNC3	TX Relay	O
FNC4	Scrambler	O
FNC5	Scrambler Code1 (1)	O
FNC6	Scrambler Code2 (2)	O
FNC7	Scrambler Code3 (4)	O
FNC8	Scrambler Code4 (8)	O

Port Function is Low Active. (Exclude : Scrambler Code)

## CN3

No.	Name	I/O	Function
1	IGN	I	Ignition sens input
2	DATAI	I	External transmit signal input
3	DETO	O	FM detector output
4	TXAFI	I	TX audio input from scrambler board
5	TXAFO	O	TX audio output to scrambler board
6	EMGMIC	I	Emergency MIC input (1kHz/1.2mVrms)
7	RXAFO	O	RX audio output to scrambler board
8	ALTI	I	External alert tone signal input
9	RXAFI	I	RX audio input from scrambler board
10	5C	O	5V DC power supply (50mA MAX)
11	8C	O	8V DC power supply (50mA MAX)

# TK-8102 PC BOARD

DISPLAY UNIT (X54-3460-20) Component side view (J72-0916-09)

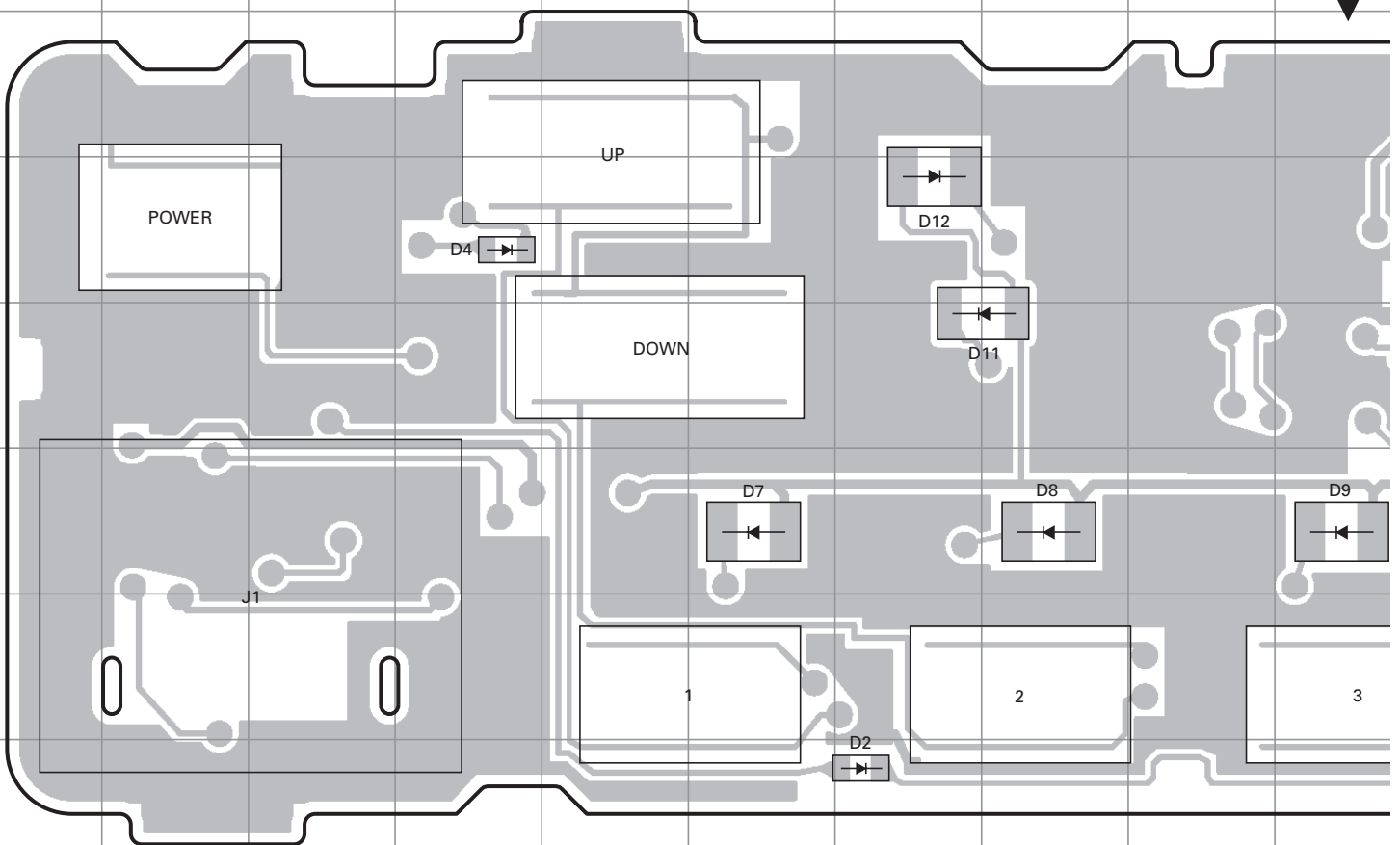

DISPLAY UNIT (X54-3460-20) Foil side view (J72-0916-09)

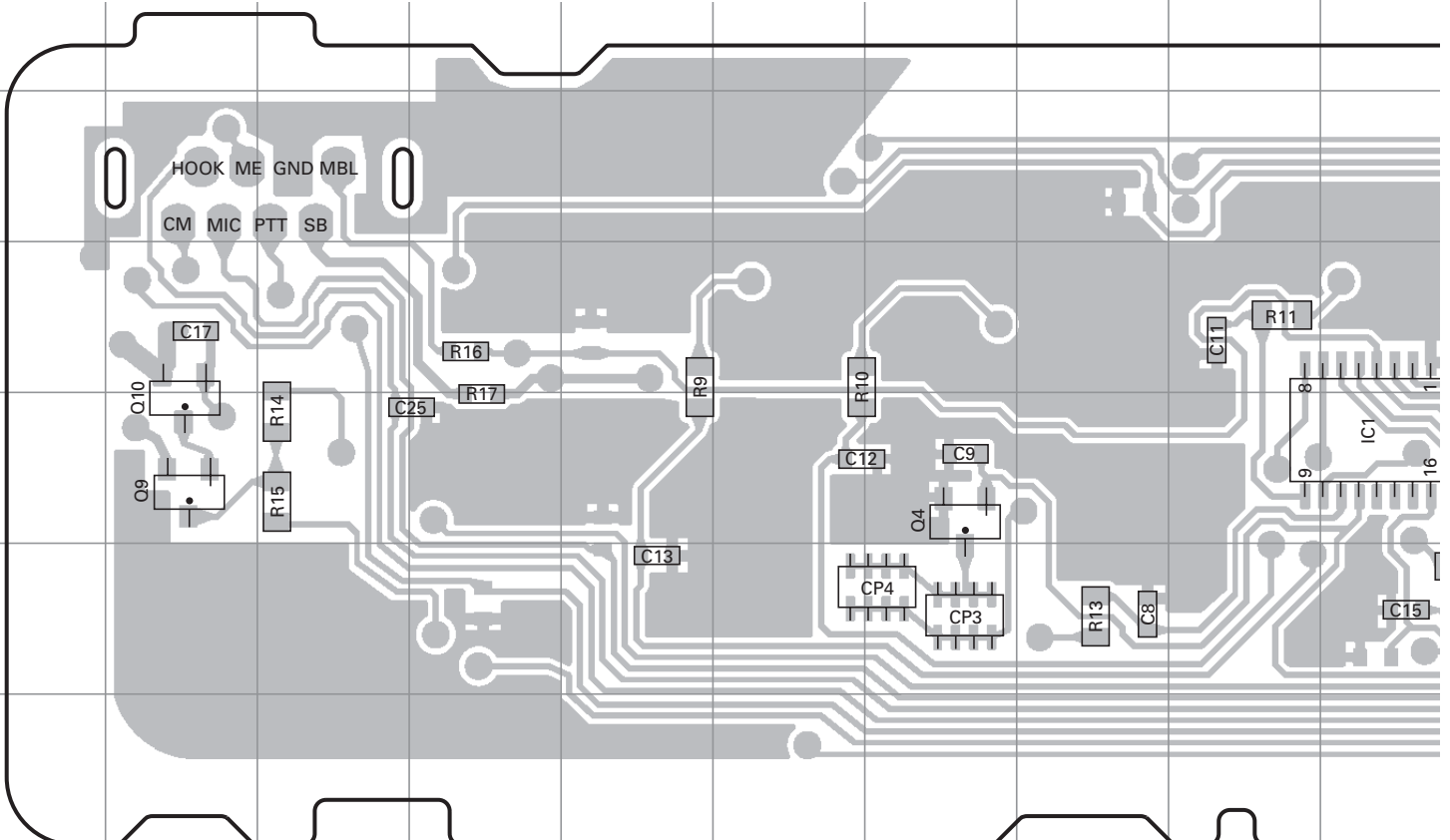

# PC BOARD TK-8102

**DISPLAY UNIT (X54-3460-20) Component side view (J72-0916-09)**

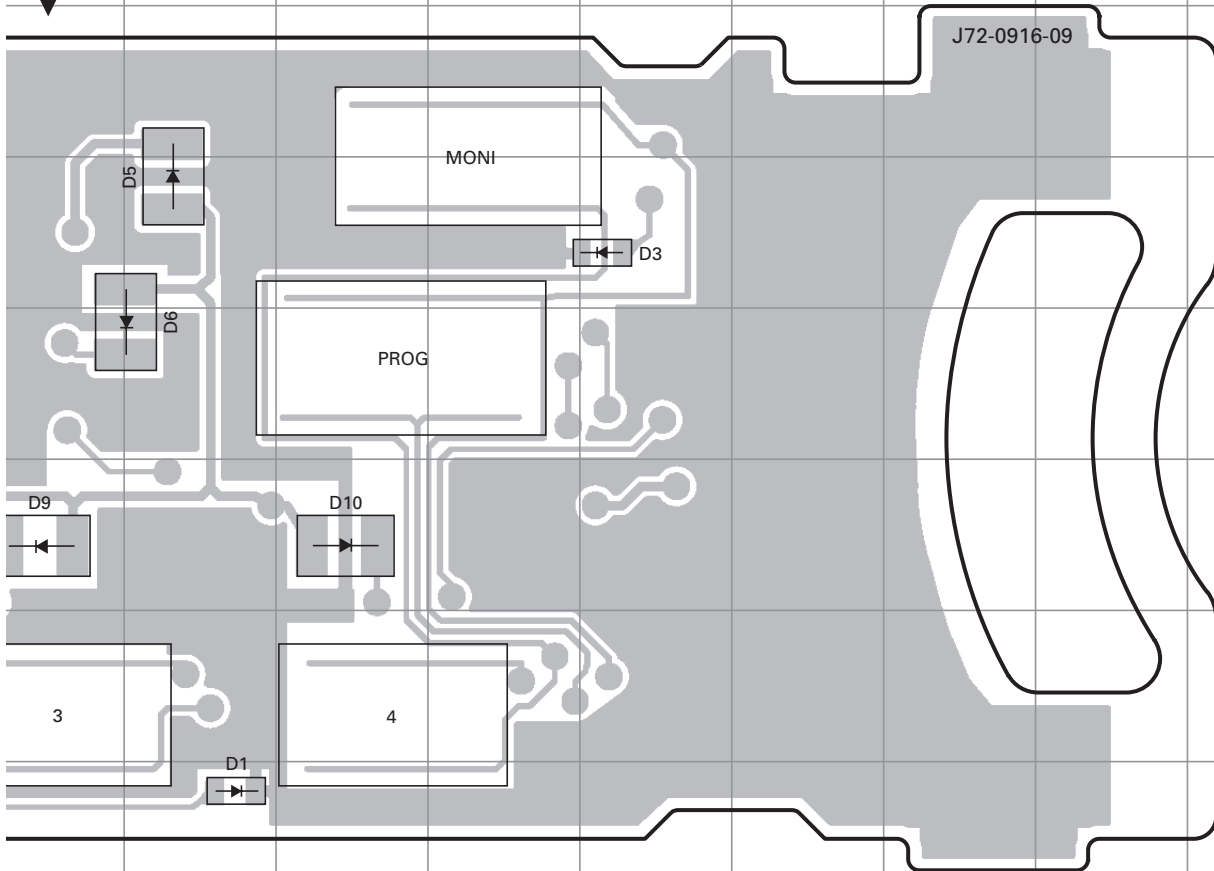

Ref. No.	Address
D1	7K
D2	7G
D3	3N
D4	3D
D5	3K
D6	4K
D7	5F
D8	5H
D9	5J
D10	5L
D11	4H
D12	3G

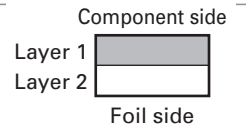

**DISPLAY UNIT (X54-3460-20) Foil side view (J72-0916-09)**

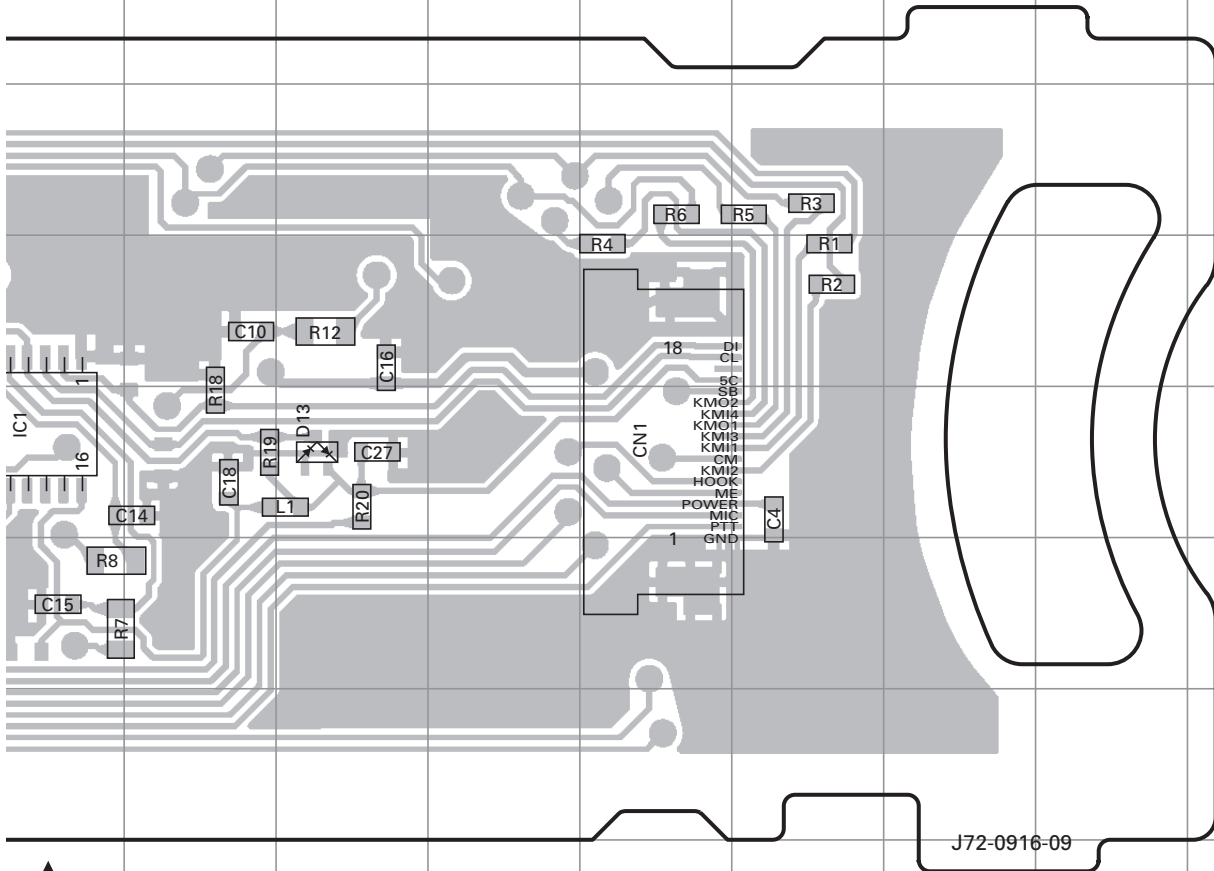

Ref. No.	Address
IC1	11J
Q4	11G
Q9	11B
Q10	11B
D13	11L

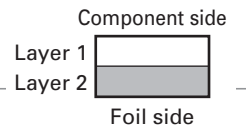

# TK-8102 PC BOARD

DISPLAY UNIT (X54-3460-20) Component side view (J72-0916-09)

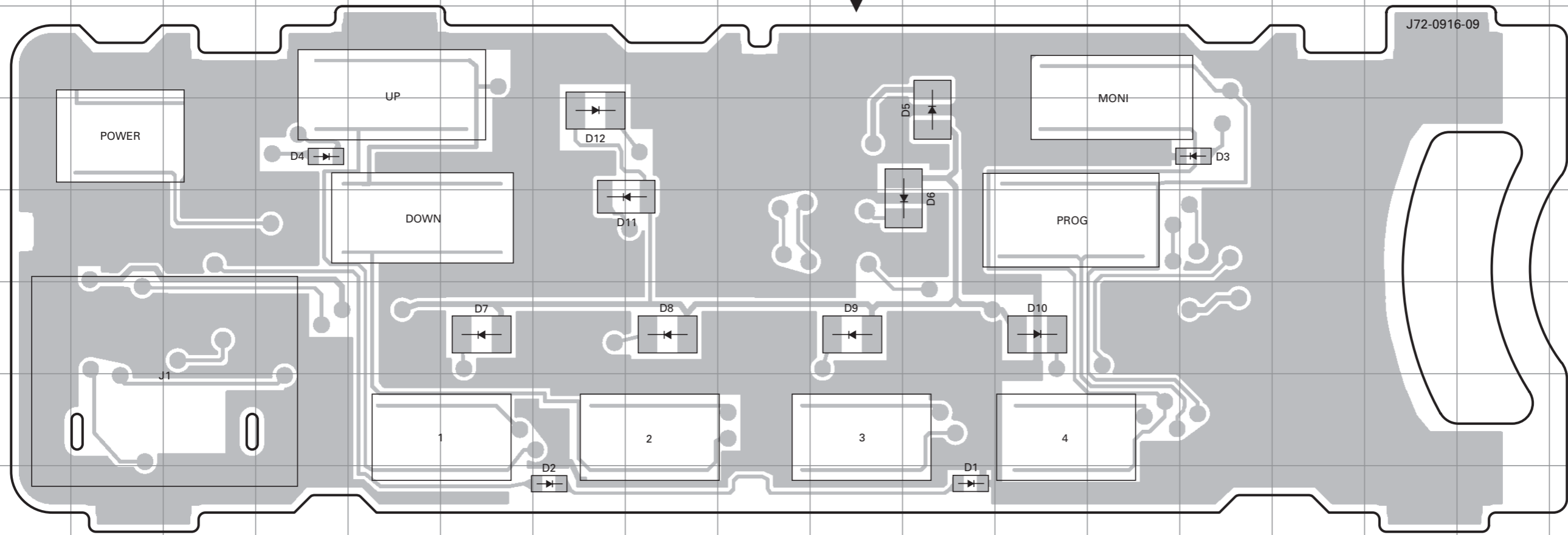

Ref. No.	Address
D1	7K
D2	7G
D3	3N
D4	3D
D5	3K
D6	4K
D7	5F
D8	5H
D9	5J
D10	5L
D11	4H
D12	3G

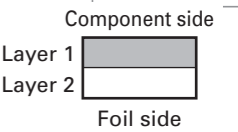

DISPLAY UNIT (X54-3460-20) Foil side view (J72-0916-09)

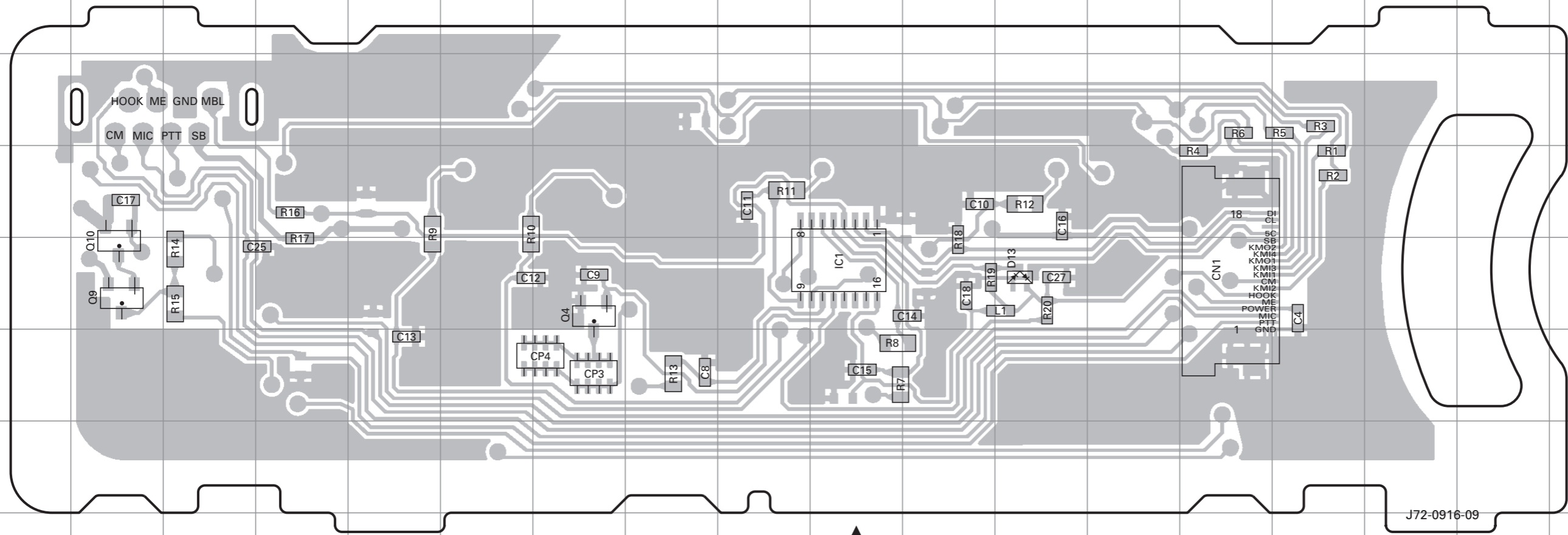

Ref. No.	Address
IC1	11J
Q4	11G
Q9	11B
Q10	11B
D13	11L

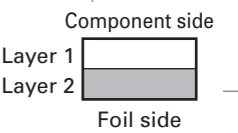

# TK-8102 PC BOARD

TX-RX UNIT (X57-6920-XX) -22 : M -23 : M2 -24 : M3  
 Component side view (J72-0918-09)

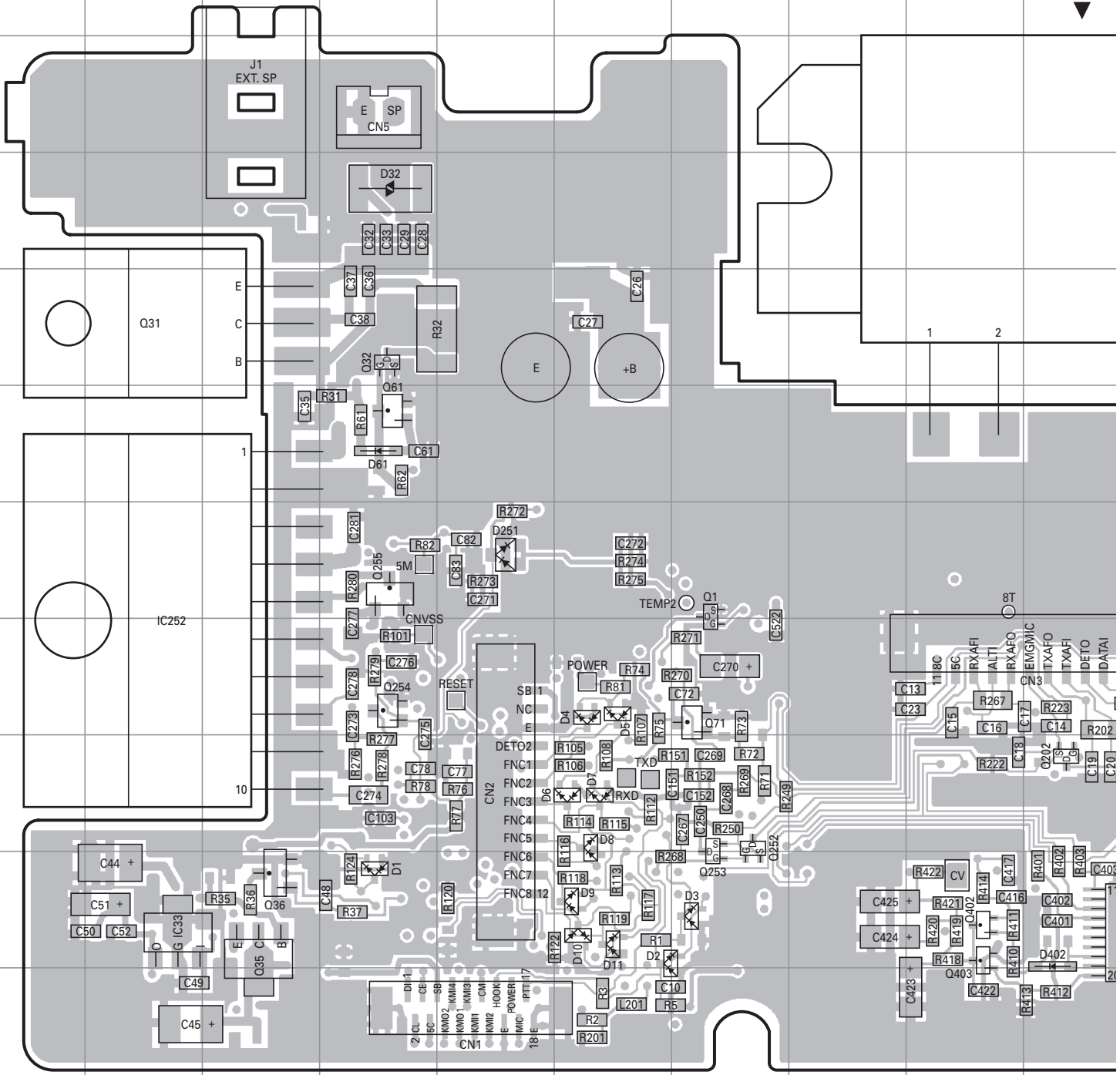

Ref. No.	Address	Ref. No.	Address	Ref. No.	Address	Ref. No.	Address	Ref. No.	Address	Ref. No.	Address	Ref. No.	Address
IC33	10B	IC502	4K	Q201	8Q	Q402	10I	D7	9F	D202	7P	D608	5Q
IC161	8O	Q1	7G	Q202	9J	Q403	10I	D8	9F	D251	7E	D609	6S
IC201	8R	Q31	5B	Q252	9G	D1	10D	D9	10F	D302	10P		
IC202	8R	Q32	5D	Q253	10G	D2	10F	D10	10F	D303	9Q		
IC203	10R	Q35	10C	Q254	8D	D3	10G	D11	10F	D401	10J		
IC252	8B	Q36	10C	Q255	7D	D4	8F	D32	4D	D402	10J		
IC401	10J	Q61	6D	Q302	11L	D5	8F	D61	6D	D606	5P		
IC501	6R	Q71	8G	Q351	10O	D6	9F	D201	8P	D607	4P		





# TK-8102 PC BOARD

# PC BOARD TK-8102

TX-RX UNIT (X57-6920-XX) -22 : M -23 : M2 -24 : M3  
Component side view (J72-0918-09)

TX-RX UNIT (X57-6920-XX) -22 : M -23 : M2 -24 : M3  
Component side view (J72-0918-09)

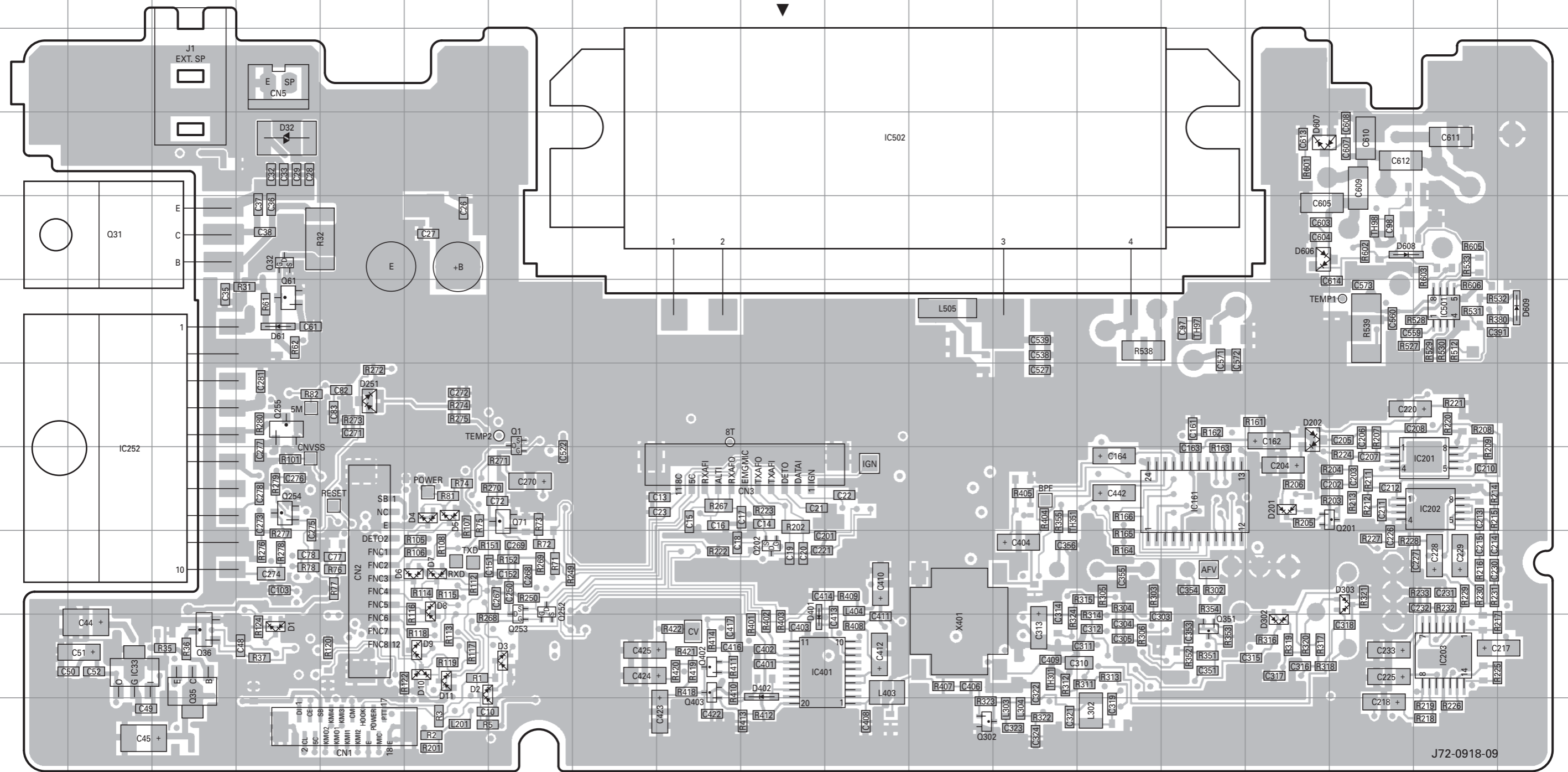

J72-0918-09

Ref. No.	Address	Ref. No.	Address	Ref. No.	Address	Ref. No.	Address	Ref. No.	Address	Ref. No.	Address	Ref. No.	Address
IC33	10B	IC502	4K	Q201	8Q	Q402	10I	D7	9F	D202	7P	D608	5Q
IC161	8O	Q1	7G	Q202	9J	Q403	10I	D8	9F	D251	7E	D609	6S
IC201	8R	Q31	5B	Q252	9G	D1	10D	D9	10F	D302	10P		
IC202	8R	Q32	5D	Q253	10G	D2	10F	D10	10F	D303	9Q		
IC203	10R	Q35	10C	Q254	8D	D3	10G	D11	10F	D401	10J		
IC252	8B	Q36	10C	Q255	7D	D4	8F	D32	4D	D402	10J		
IC401	10J	Q61	6D	Q302	11L	D5	8F	D61	6D	D606	5P		
IC501	6R	Q71	8G	Q351	10O	D6	9F	D201	8P	D607	4P		

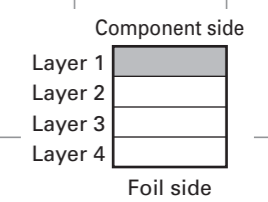

# TK-8102 PC BOARD

TX-RX UNIT (X57-6920-XX) -22 : M -23 : M2 -24 : M3  
Foil side view (J72-0918-09)

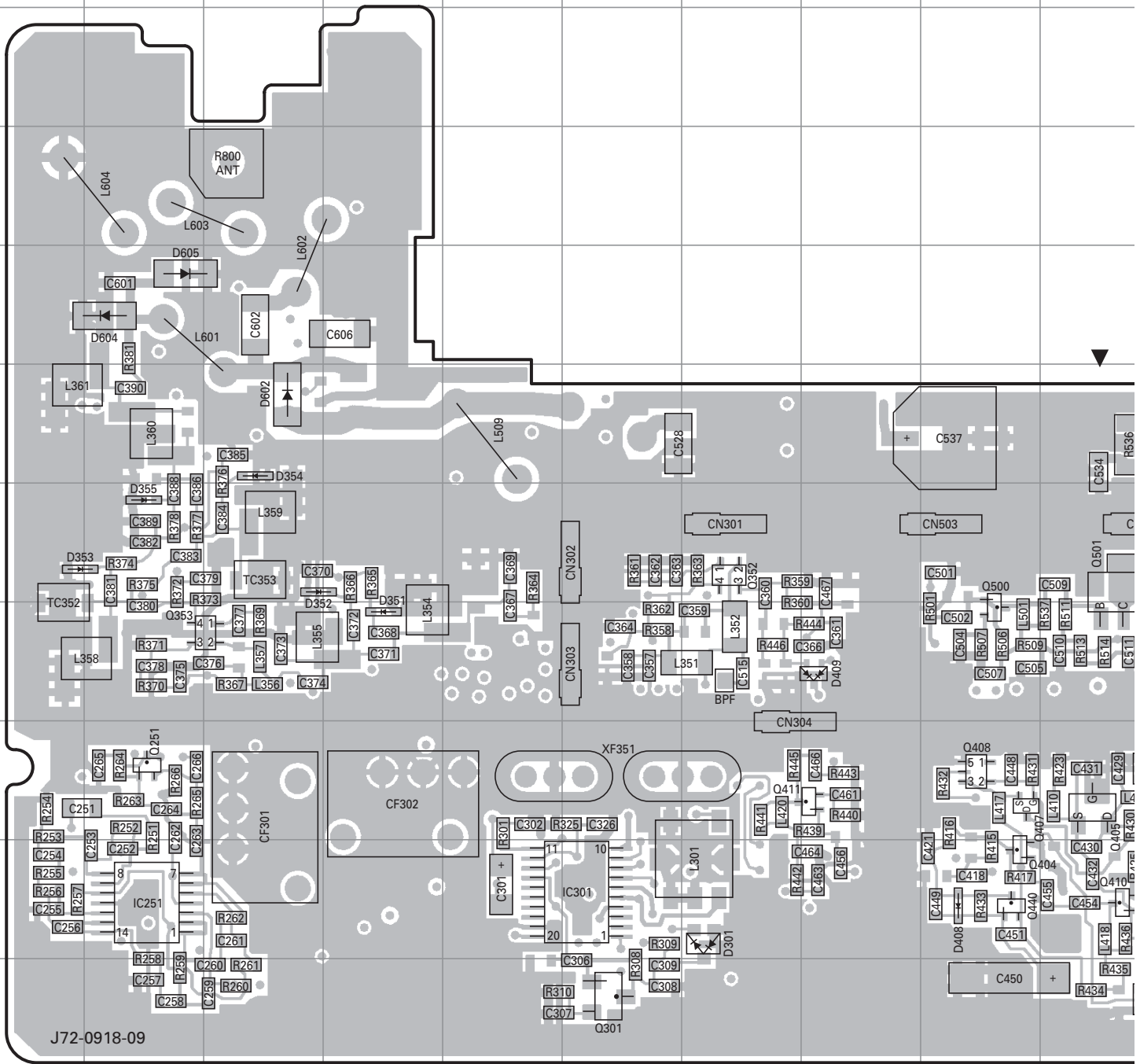

Ref. No.	Address	Ref. No.	Address	Ref. No.	Address	Ref. No.	Address	Ref. No.	Address	Ref. No.	Address
IC31	10R	Q33	10Q	Q404	10I	Q500	8I	D354	6C	D409	8H
IC32	11Q	Q34	10Q	Q405	9J	Q501	7J	D355	7B	D502	8K
IC34	11N	Q86	8O	Q406	10K	Q502	8L	D403	9L	D503	6K
IC35	10M	Q87	8P	Q407	9I	D31	4O	D404	9K	D602	6C
IC66	9M	Q251	9B	Q408	9I	D301	10G	D405	10L	D604	5B
IC101	9O	Q301	11F	Q410	10J	D351	8D	D406	10L	D605	5B
IC251	10B	Q352	7G	Q411	9H	D352	7C	D407	10L		
IC301	10F	Q353	8B	Q440	10I	D353	7A	D408	10I		

# PC BOARD TK-8102

TX-RX UNIT (X57-6920-XX) -22 : M -23 : M2 -24 : M3  
Foil side view (J72-0918-09)

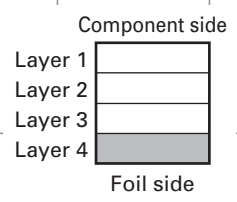
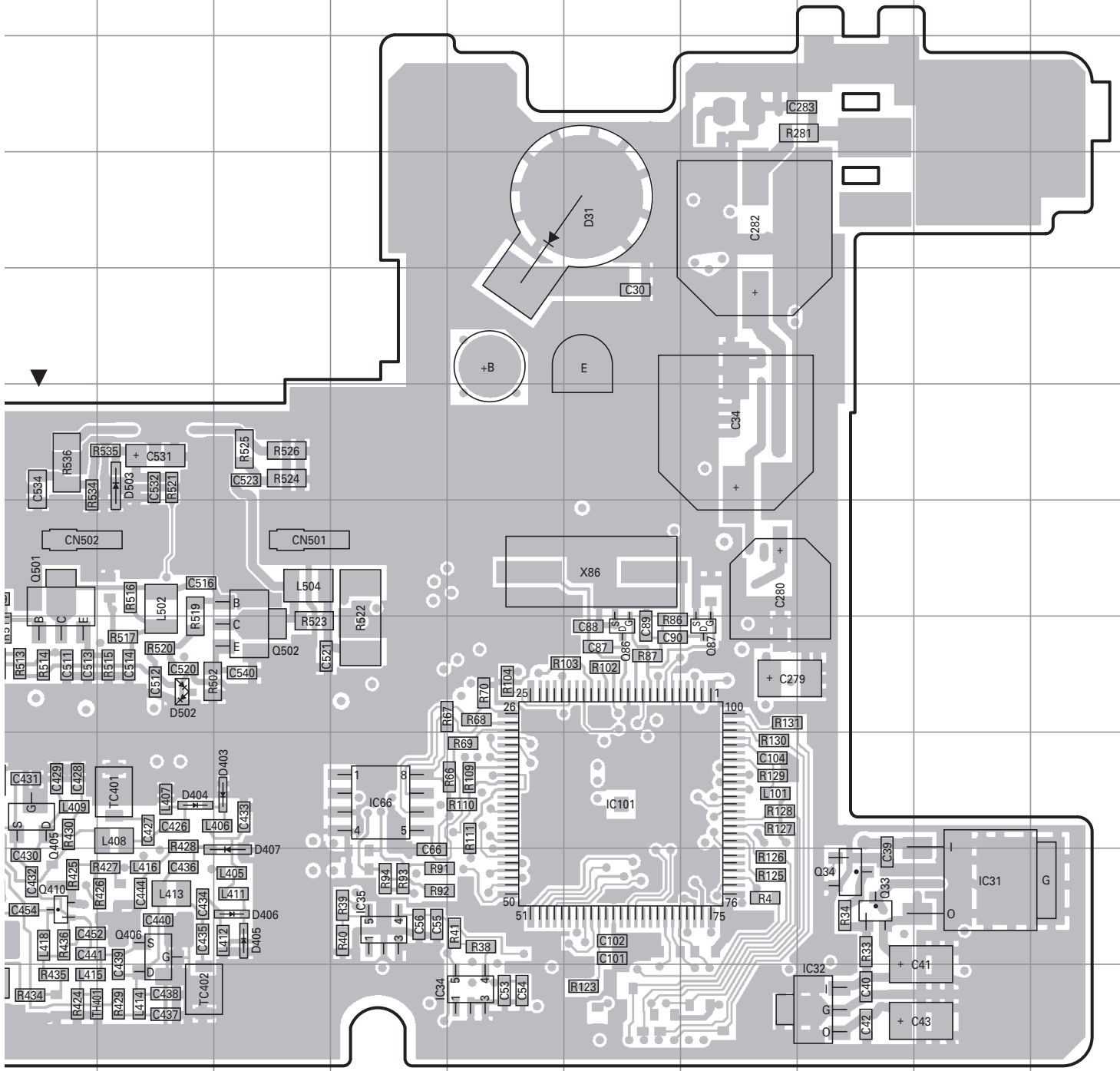





# TK-8102 SCHEMATIC DIAGRAM

TX-RX UNIT (X57-6920-XX)

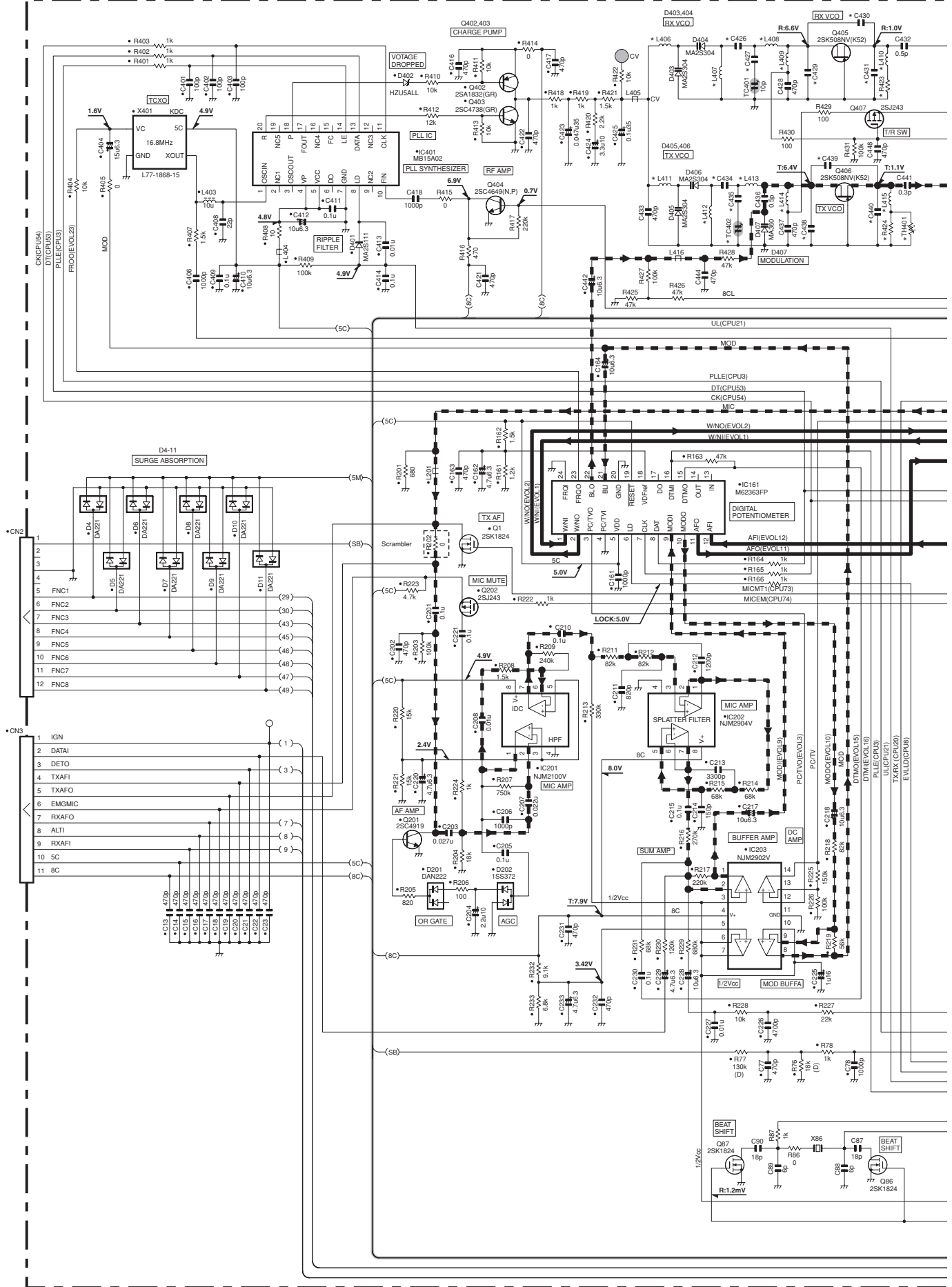







# SCHEMATIC DIAGRAM TK-8102

DISPLAY UNIT (X54-3460-20)

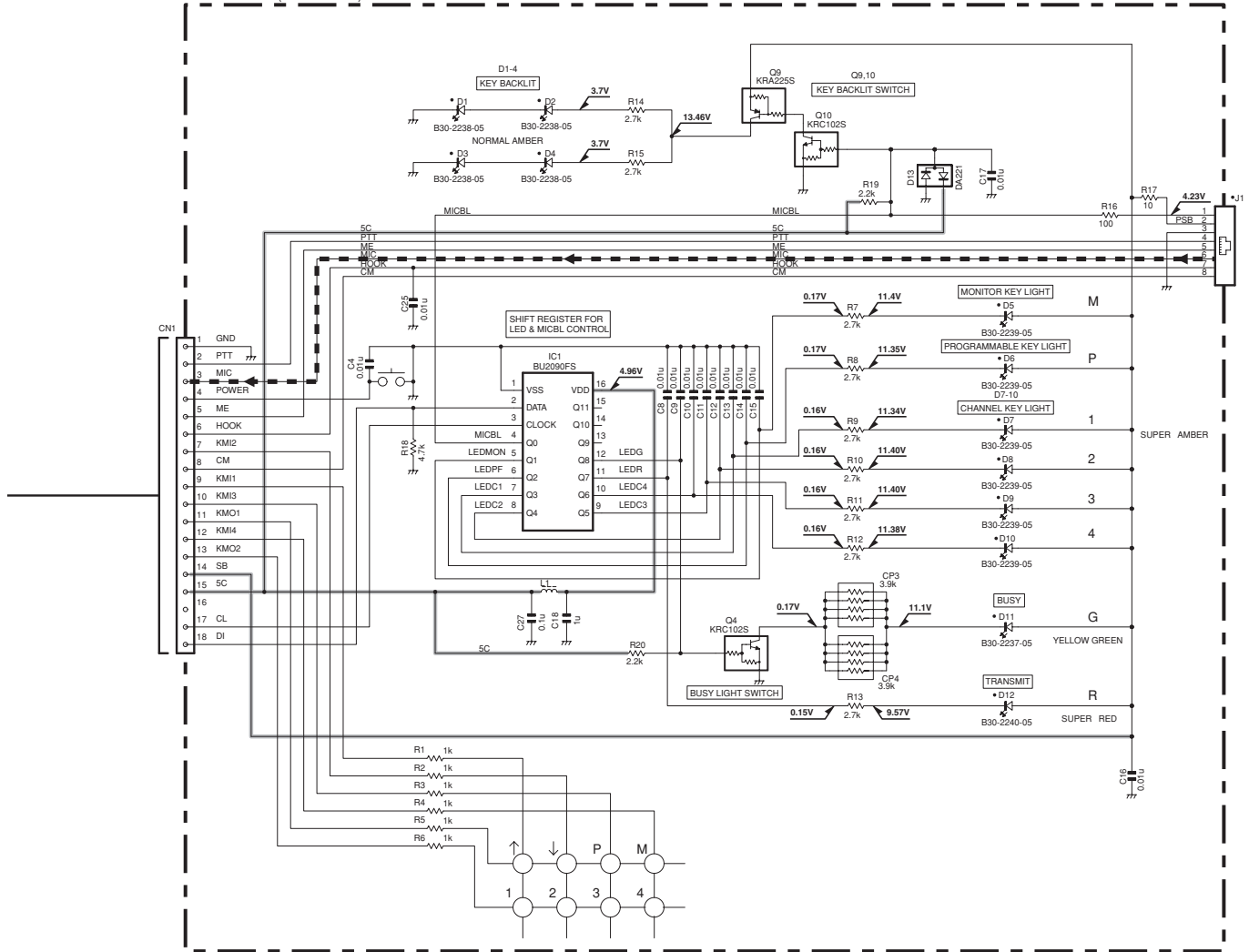

X57-6920-XX	C48	C303	C304	C305	C367	C369	C373	C381	C384	C386	C388	C390	C426	C427	C429	C430	C431	C434	C435	C438	C439	C440		
-22	M	450-490MHz	0.047u	4700p	220p	220p	470p	1.5p	9p	7p	7p	0.5p	9p	18p	12p	1p	6p	5p	8p	6p	1p	3p	4p	
-23	M2	485-520MHz	0.01u	4700p	220p	220p	47p	6p	7p	6p	5p	0.5p	3p	5p	4p	2p	2p	3p	4p	3p	1.5p	2p	3p	
-24	M3	400-430MHz	0.01u	1000p	120p	120p	470p	NO	8p	7p	7p	0.75p	6p	8p	8p	7p	2p	2p	3p	5p	6p	2p	2p	3p

X57-6910-XX	C502	C523	C528	C601	C604	C605	C610	C611	C612	R304	R305	R306	R311	R312	R381	R423	R424	R502	R506	TC352	TC402	TH401		
-22	M	450-490MHz	2p	4p	NO	NO	1.5p	2p	6p	4p	1p	4.7k	1.8k	270k	33k	47k	0	220	150	10	56k	6p	10p	10k
-23	M2	485-520MHz	2p	4p	2p	3p	2p	1p	4p	3p	2p	4.7k	1.8k	270k	27k	150k	0	270	220	33	56k	6p	10p	NO
-24	M3	400-430MHz	5p	7p	NO	5p	2p	2p	7p	6p	2p	12k	18k	220k	33k	47k	10	330	270	10	120k	3p	6p	NO

X57-6910-XX	L354	L355	L356	L358	L359	L406	L407	L408	L409	L410	L411	L412	L413	L414	L415	L504	D351	D352	D353	D354	D355			
-22	M	450-490MHz	8n	8n	18n	8n	8n	4.7u	4.7u	27n	4.7u	4.7u	27u	27u	27n	27u	27n	27u	12n	HVC350B	HVC350B	HVC350B	HVC350B	HVC350B
-23	M2	485-520MHz	5n	8n	18n	5n	8n	270n	270n	39n	180n	270n	270n	270n	33n	180n	270n	270n	12n	HVC355B	HVC355B	HVC355B	HVC355B	HVC355B
-24	M3	400-430MHz	12.5n	12.5n	22n	12.5n	12.5n	270n	270n	56n	270n	270n	270n	270n	47n	180n	270n	22n	HVC350B	HVC350B	HVC355B	HVC350B	HVC350B	

**Note : The components marked with a dot (•) are parts of layer 1.**



## BLOCK DIAGRAM

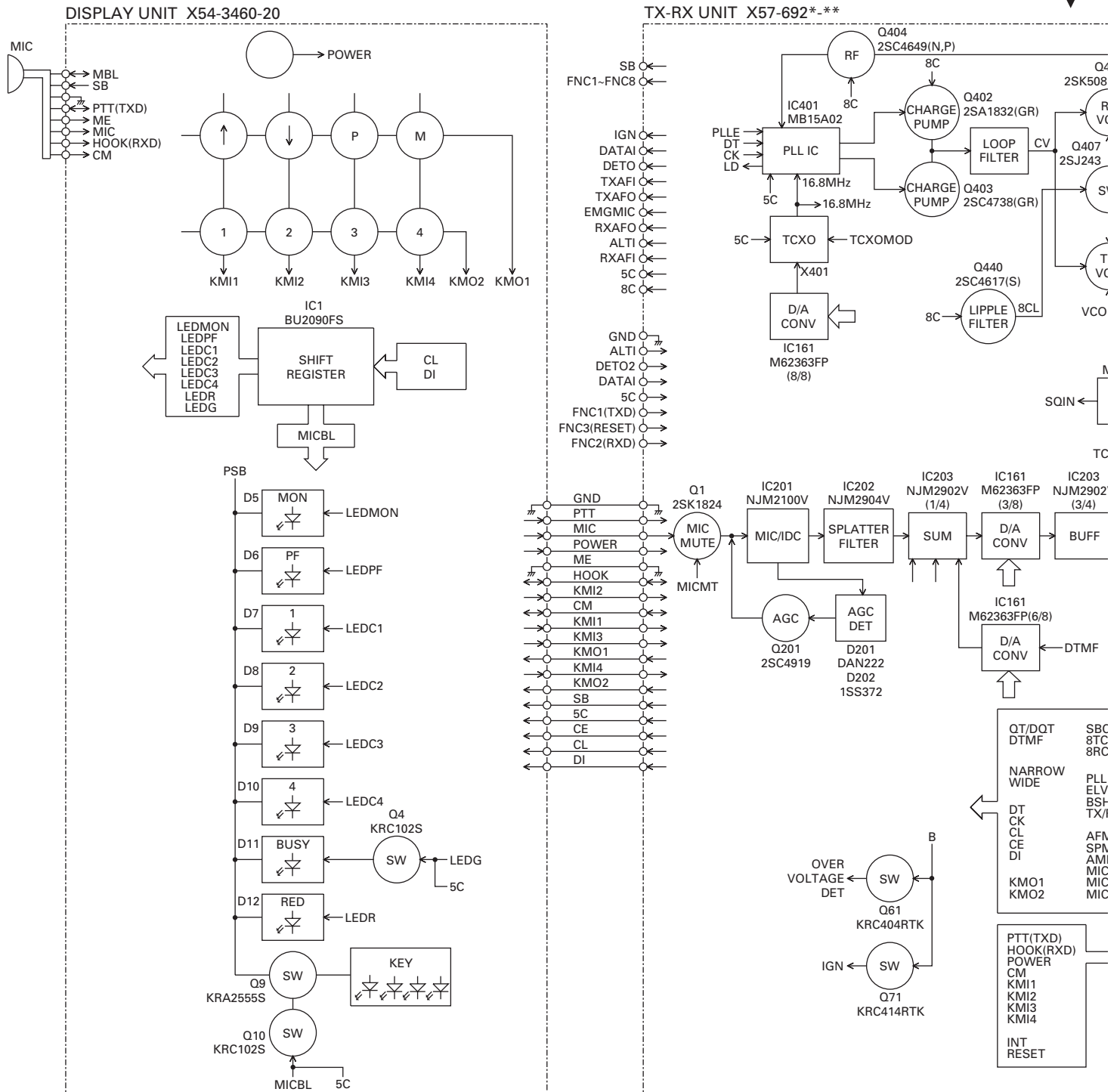

## BLOCK DIAGRAM

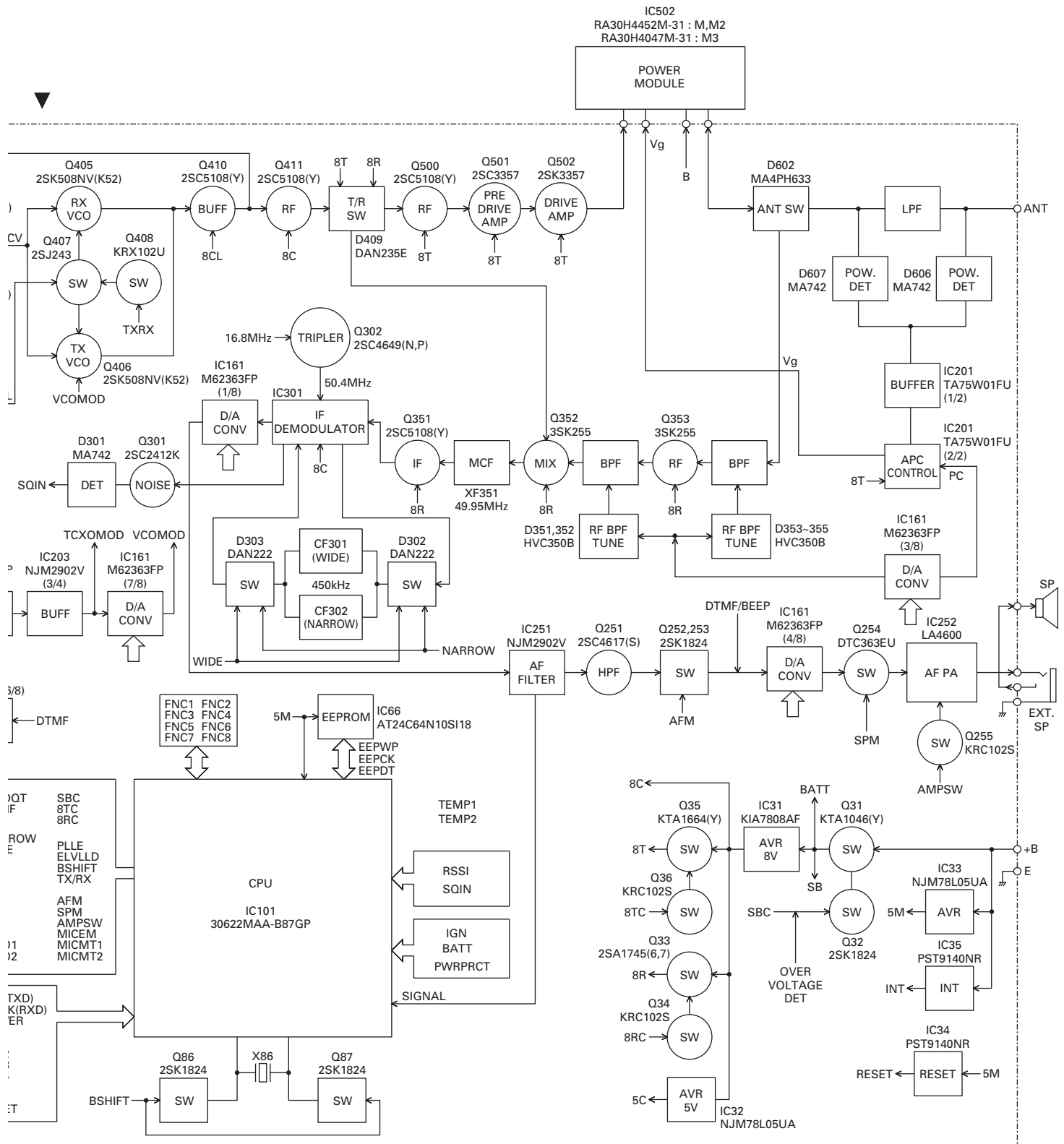



## LEVEL DIAGRAM

### Receiver Section

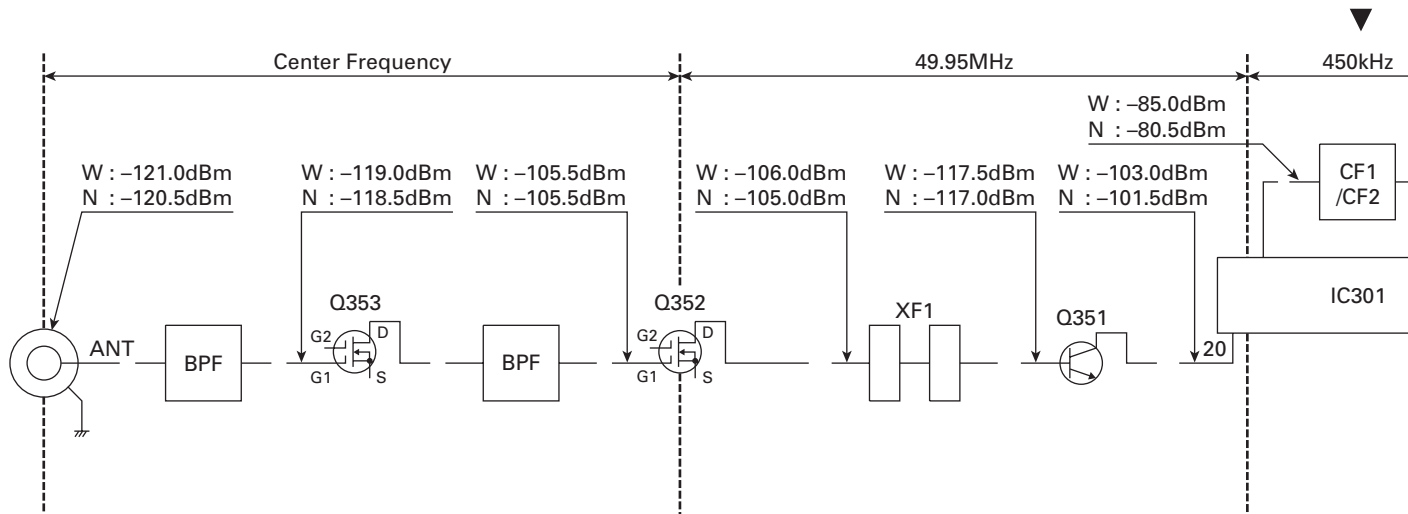

To make measurements in the RF section, connect the RF level meter. In the RF section, use a 0.01 $\mu$ F coupling capacitor. (The display shows the SSG input value required to obtain 12dB SIN/

### Transmitter Section

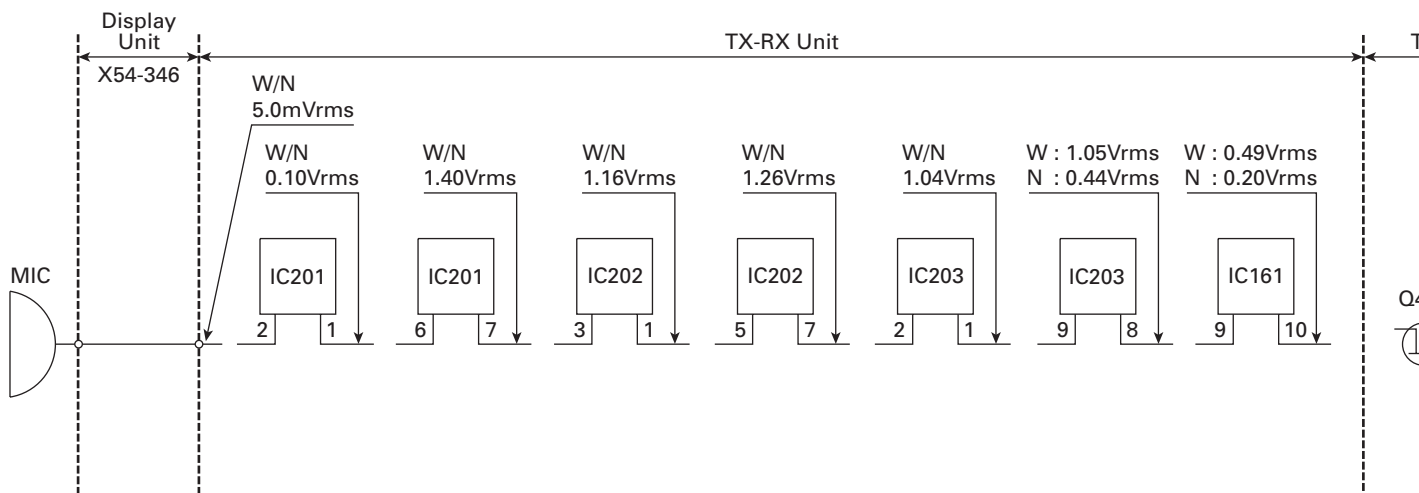

To make measurements in the AF section, connect the AC level meter. AG is set so that MIC input becomes 3kHz/1.5kHz (Wide/Narrow) DEV at 1kHz MOD.

## LEVEL DIAGRAM

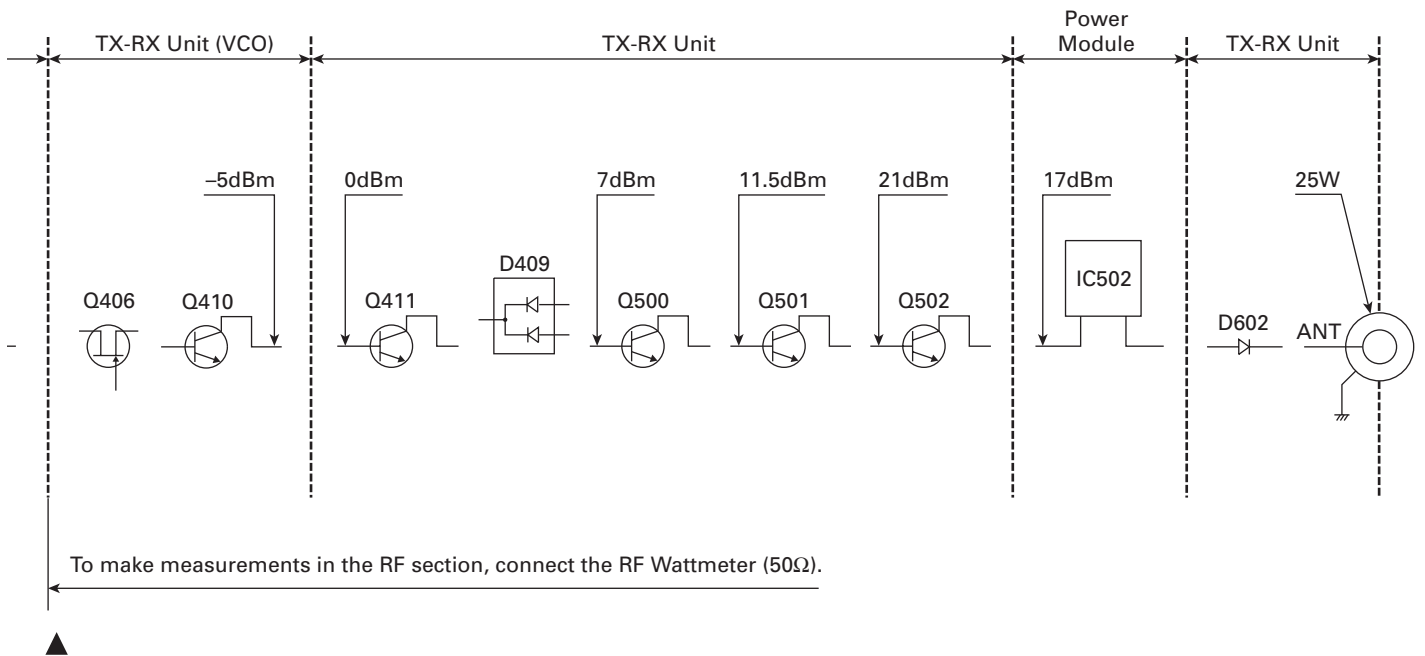
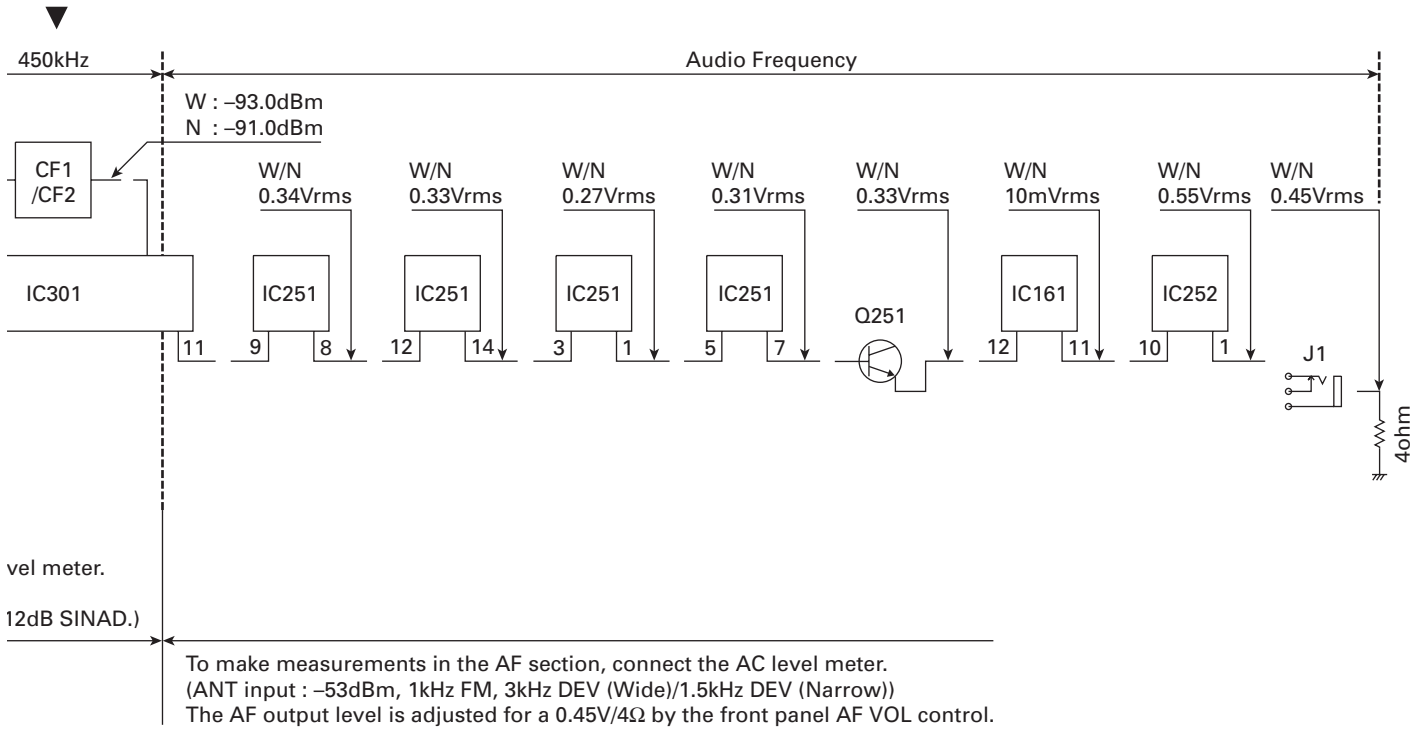



## SPECIFICATIONS

### GENERAL

Frequency Range .....	M : 450 to 490MHz	M2 : 485 to 520MHz	M3 : 400 to 430MHz
Channels / Groups .....	4 channels		
Channel Spacing .....	Wide : 25kHz	Narrow : 12.5kHz	
PLL Channel Stepping .....	5.0, 6.25kHz		
Operating Voltage .....	13.6V DC $\pm$ 15%		
Current Drain .....	Less than 0.4A on standby Less than 1.0A on receive Less than 8.0A on transmit		
Operating Temperature Range .....	-30°C to +60°C		
Dimensions & Weight .....	160 W x 43 H x 107 D mm, 1.0kg		
Channel Frequency Spread .....	M : 40MHz	M2 : 35MHz	M3 : 30MHz

### RECEIVER (Measurements made per EIA standard EIA/TIA-603)

Sensitivity (12dB SINAD) .....	Wide : 0.28 $\mu$ V	Narrow : 0.35 $\mu$ V
Selectivity .....	Wide : 75dB	Narrow : 65dB
Intermodulation .....	Wide : 70dB	Narrow : 60dB
Spurious Response .....	75dB	
Audio Power Output .....	4.0W	
Frequency Stability .....	$\pm$ 2.5ppm	

### TRANSMITTER (Measurements made per EIA standard EIA/TIA-603)

RF Power Output .....	High : 25W	Low : 5W
Spurious and Harmonics .....	70dB	
Modulation .....	Wide : 16K0F3E	Narrow : 11K0F3E
FM Noise .....	Wide : 45dB	Narrow : 40dB
Audio Distortion .....	Less than 3%	
Frequency Stability .....	$\pm$ 2.5ppm	

## KENWOOD CORPORATION

2967-3, Ishikawa-machi, Hachioji-shi, Tokyo, 192-8525 Japan

### KENWOOD U.S.A. CORPORATION

P.O. BOX 22745, 2201 East Dominguez Street, Long Beach, CA 90801-5745, U.S.A.

### KENWOOD ELECTRONICS CANADA INC.

6070 Kestrel Road, Mississauga, Ontario, Canada L5T 1S8

### KENWOOD ELECTRONICS DEUTSCHLAND GMBH

Rembrücker Str. 15, 63150 Heusenstamm, Germany

### KENWOOD ELECTRONICS BELGIUM N.V.

Leuvensesteenweg 248 J, 1800 Vilvoorde, Belgium

### KENWOOD ELECTRONICS FRANCE S.A.

13, Boulevard Ney, 75018 Paris, France

### KENWOOD ELECTRONICS U.K. LIMITED

KENWOOD House, Dwight Road, Watford, Herts., WD18 9EB United Kingdom

### KENWOOD ELECTRONICS EUROPE B.V.

Amsterdamseweg 37, 1422 AC Uithoorn, The Netherlands

### KENWOOD ELECTRONICS ITALIA S.p.A.

Via G. Sirtori, 7/9 20129 Milano, Italy

### KENWOOD IBERICA S.A.

Bolivia, 239-08020 Barcelona, Spain

### KENWOOD ELECTRONICS AUSTRALIA PTY. LTD.

(A.C.N. 001 499 074)

16 Giffnock Avenue, Centrecourt Estate, North Ryde, N.S.W. 2113 Australia

### KENWOOD ELECTRONICS (HONG KONG) LTD.

Unit 3712-3724, Level 37, Tower one Metroplaza, 223 Hing Fong Road, Kwai Fong, N.T., Hong Kong

### KENWOOD ELECTRONICS SINGAPORE PTE LTD.

1 Genting Lane #07-00 Kenwood Building, Singapore 349544

